

# JVC

## SERVICE MANUAL

### COLOUR TELEVISION

BASIC CHASSIS

CG

# AV-21AT

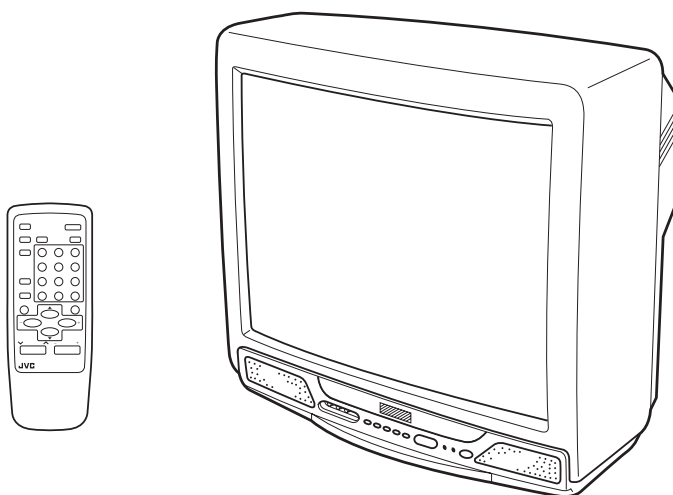

## CONTENTS

■ SPECIFICATIONS .....	2
■ SAFETY PRECAUTIONS .....	3
■ FEATURES .....	4
★ OPERATING INSTRUCTIONS (APPENDED) .....	1-1
■ SPECIFIC SERVICE INSTRUCTIONS .....	4
■ SERVICE ADJUSTMENTS .....	10
★ STANDARD CIRCUIT DIAGRAM (APPENDED) .....	2-1
■ PARTS LIST .....	27

# SPECIFICATIONS

Item		Content
<b>Dimensions (W × H × D)</b>		502mm × 451mm × 480.5mm
<b>Mass</b>		19.5kg
<b>TV RF System</b>		B / G, I, D / K, K1
<b>Colour System</b>	TV Mode	PAL / SECAM
	VIDEO Mode	PAL / SECAM / NTSC3.58 / NTSC4.43
<b>Receiving Frequency</b>	VHF (VL)	46.25MHz ~ 168.25MHz
	VHF (VH)	175.25MHz ~ 463.25MHz
	UHF	471.25MHz ~ 863.25MHz
	CATV	● Cable TVs of Mid (X-Z, S1-S10) Super (S11-S20) & Hyper (S21-S41) bands receivable
<b>Intermediate Frequency</b>	VIF Carrier	38.0MHz
	SIF Carrier	31.5MHz (6.5MHz) 32.0MHz (6.0MHz) 32.5MHz (5.5MHz) 33.5MHz (4.5MHz)
<b>Colour Sub Carrier Frequency</b>		PAL (4.43MHz) SECAM (4.40625MHz / 4.25MHz) NTSC (3.58MHz / 4.43MHz)
<b>Aerial Input Terminal</b>		75Ω Unbalanced
<b>Power Input</b>		AC110 ~ 240V, 50 / 60Hz
<b>Power Consumption</b>		105W (Max.)/68W (Avg.)
<b>Picture Tube</b>		Visible size : 51cm measured diagonally
<b>High Voltage</b>		26.5kV ± 1.5kV (at zero beam current)
<b>Speaker</b>		5cm × 9 cm Oval type × 2
<b>Audio Output</b>		5W (Monaural)
<b>Input</b>	Video	1Vp-p, 75Ω
	Audio	500mVrms (-4dBs), High impedance
<b>Output</b>	Video	1Vp-p, 75Ω
	Audio	500mVrms (-4dBs), Low impedance
<b>Headphone Jack</b>		Stereo mini jack (3.5ø)
<b>Remote Control Unit</b>		RM-C364-1H (Battery size : AA/R06/UM-3 × 2)

*Design & specifications are subject to change without notice.*

# SAFETY PRECAUTIONS

- The design of this product contains special hardware, many circuits and components specially for safety purposes. For continued protection, no changes should be made to the original design unless authorized in writing by the manufacturer. Replacement parts must be identical to those used in the original circuits. Service should be performed by qualified personnel only.
- Alterations of the design or circuitry of the products should not be made. Any design alterations or additions will void the manufacturer's warranty and will further relieve the manufacturer of responsibility for personal injury or property damage resulting therefrom.
- Many electrical and mechanical parts in the products have special safety-related characteristics. These characteristics are often not evident from visual inspection nor can the protection afforded by them necessarily be obtained by using replacement components rated for higher voltage, wattage, etc. Replacement parts which have these special safety characteristics are identified in the parts list of Service manual. **Electrical components having such features are identified by shading on the schematics and by (Δ) on the parts list in Service manual.** The use of a substitute replacement which does not have the same safety characteristics as the recommended replacement part shown in the parts list of Service manual may cause shock, fire, or other hazards.
- Don't short between the LIVE side ground and ISOLATED (NEUTRAL) side ground or EARTH side ground when repairing.**  
Some model's power circuit is partly different in the GND. The difference of the GND is shown by the LIVE : (⊥) side GND, the ISOLATED (NEUTRAL) : (↷) side GND and EARTH : (⊕) side GND. Don't short between the LIVE side GND and ISOLATED (NEUTRAL) side GND or EARTH side GND and never measure with a measuring apparatus (oscilloscope etc.) the LIVE side GND and ISOLATED (NEUTRAL) side GND or EARTH side GND at the same time.  
If above note will not be kept, a fuse or any parts will be broken.
- If any repair has been made to the chassis, it is recommended that the B1 setting should be checked or adjusted (See ADJUSTMENT OF B1 POWER SUPPLY).
- The high voltage applied to the picture tube must conform with that specified in Service manual. Excessive high voltage can cause an increase in X-Ray emission, arcing and possible component damage, therefore operation under excessive high voltage conditions should be kept to a minimum, or should be prevented. If severe arcing occurs, remove the AC power immediately and determine the cause by visual inspection (incorrect installation, cracked or melted high voltage harness, poor soldering, etc.). To maintain the proper minimum level of soft X-Ray emission, components in the high voltage circuitry including the picture tube must be the exact replacements or alternatives approved by the manufacturer of the complete product.
- Do not check high voltage by drawing an arc. Use a high voltage meter or a high voltage probe with a VTVM. Discharge the picture tube before attempting meter connection, by connecting a clip lead to the ground frame and connecting the other end of the lead through a 10kΩ 2W resistor to the anode button.
- When service is required, observe the original lead dress. Extra precaution should be given to assure correct lead dress in the high voltage circuit area. Where a short circuit has occurred, those components that indicate evidence of overheating should be replaced. Always use the manufacturer's replacement components.

## 9. Isolation Check

### (Safety for Electrical Shock Hazard)

After re-assembling the product, always perform an isolation check on the exposed metal parts of the cabinet (antenna terminals, video/audio input and output terminals, Control knobs, metal cabinet, screw heads, earphone jack, control shafts, etc.) to be sure the product is safe to operate without danger of electrical shock.

#### (1) Dielectric Strength Test

The isolation between the AC primary circuit and all metal parts exposed to the user, particularly any exposed metal part having a return path to the chassis should withstand a voltage of 3000V AC (r.m.s.) for a period of one second.

(. . . Withstand a voltage of 1100V AC (r.m.s.) to an appliance rated up to 120V, and 3000V AC (r.m.s.) to an appliance rated 200V or more, for a period of one second.)

This method of test requires a test equipment not generally found in the service trade.

#### (2) Leakage Current Check

Plug the AC line cord directly into the AC outlet (do not use a line isolation transformer during this check.). Using a "Leakage Current Tester", measure the leakage current from each exposed metal part of the cabinet, particularly any exposed metal part having a return path to the chassis, to a known good earth ground (water pipe, etc.). Any leakage current must not exceed 0.5mA AC (r.m.s.).

However, in tropical area, this must not exceed 0.2mA AC (r.m.s.).

#### ● Alternate Check Method

Plug the AC line cord directly into the AC outlet (do not use a line isolation transformer during this check.). Use an AC voltmeter having 1000 ohms per volt or more sensitivity in the following manner. Connect a 1500Ω 10W resistor paralleled by a 0.15μF AC-type capacitor between an exposed metal part and a known good earth ground (water pipe, etc.). Measure the AC voltage across the resistor with the AC voltmeter. Move the resistor connection to each exposed metal part, particularly any exposed metal part having a return path to the chassis, and measure the AC voltage across the resistor. Now, reverse the plug in the AC outlet and repeat each measurement. Any voltage measured must not exceed 0.75V AC (r.m.s.). This corresponds to 0.5mA AC (r.m.s.).

However, in tropical area, this must not exceed 0.3V AC (r.m.s.). This corresponds to 0.2mA AC (r.m.s.).

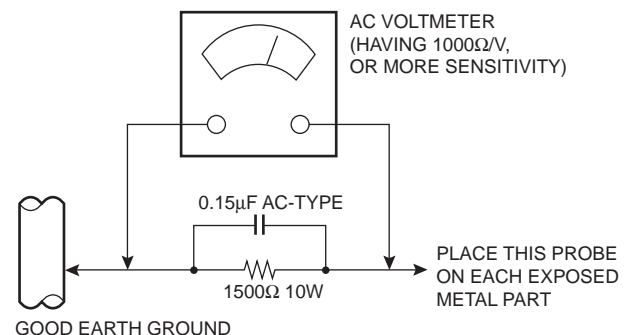

# FEATURES

- New chassis design enables use of an interactive on-screen control.
- Wide range voltage for AC power input.
- With AUDIO / VIDEO INPUT & OUTPUT terminals.
- MUTING button can reduce the audio level to zero instantly.
- Functional remote control to operate TV set (for channel select, volume control, power ON/OFF, etc.) from a distance.
- I<sup>2</sup>C bus control utilizes single chip ICs for IF, V/C (Video/Chroma) and VSM (Video Status Memory).
- By means of AUTO PROGRAM, the TV stations can be selected automatically and the TV channels can also be rearranged automatically.
- Built-in ECO MODE (ECONOMY, ECOLOGY)  
In accordance with the brightness in a room, the brightness and/or contrast of the picture can be adjusted automatically to make the optimum picture which is easy on the eye.
- Built-in ON TIMER & RETURN +.

# SPECIFIC SERVICE INSTRUCTIONS

## DISASSEMBLY PROCEDURE

### REMOVING THE REAR COVER

1. Unplug the AC power cord.
2. Remove the 6 screws marked "A" and 1 screw marked "B".
3. Withdraw the rear cover backward.

### REMOVING THE MAIN PW BOARD

- After removing the rear cover.
1. Slightly raise both sides of the Main PW Board by hand and withdraw the Main PW Board backward.  
(If necessary, take off the wire clamp, connectors etc.)

### REMOVING THE SPEAKER

- After removing the rear cover and the Main PW Board.
1. Remove the 2 screws marked "C".
  2. Follow the same step for removing the other hand speaker.

### CHECKING THE MAIN PW BOARD

To check the back side of the Main PW Board, follow the next steps.

1. Pull out the Main PW Board. (Refer to "REMOVING THE MAIN PW BOARD".)
2. Erect the Main PW Board vertically so that you can easily check the back side of it.

#### CAUTION:

- When erecting the Main PW Board, be careful so that there will be no contacting with other PW Board.
- Before turning on power, make sure that the CRT earth wire and other connectors are properly connected.

### WIRE CLAMPING AND CABLE TYING

1. Be sure to clamp the wire.
2. Never remove the cable tie used for tying the wires together.  
Should it be inadvertently removed, be sure to tie the wires with a new cable tie.

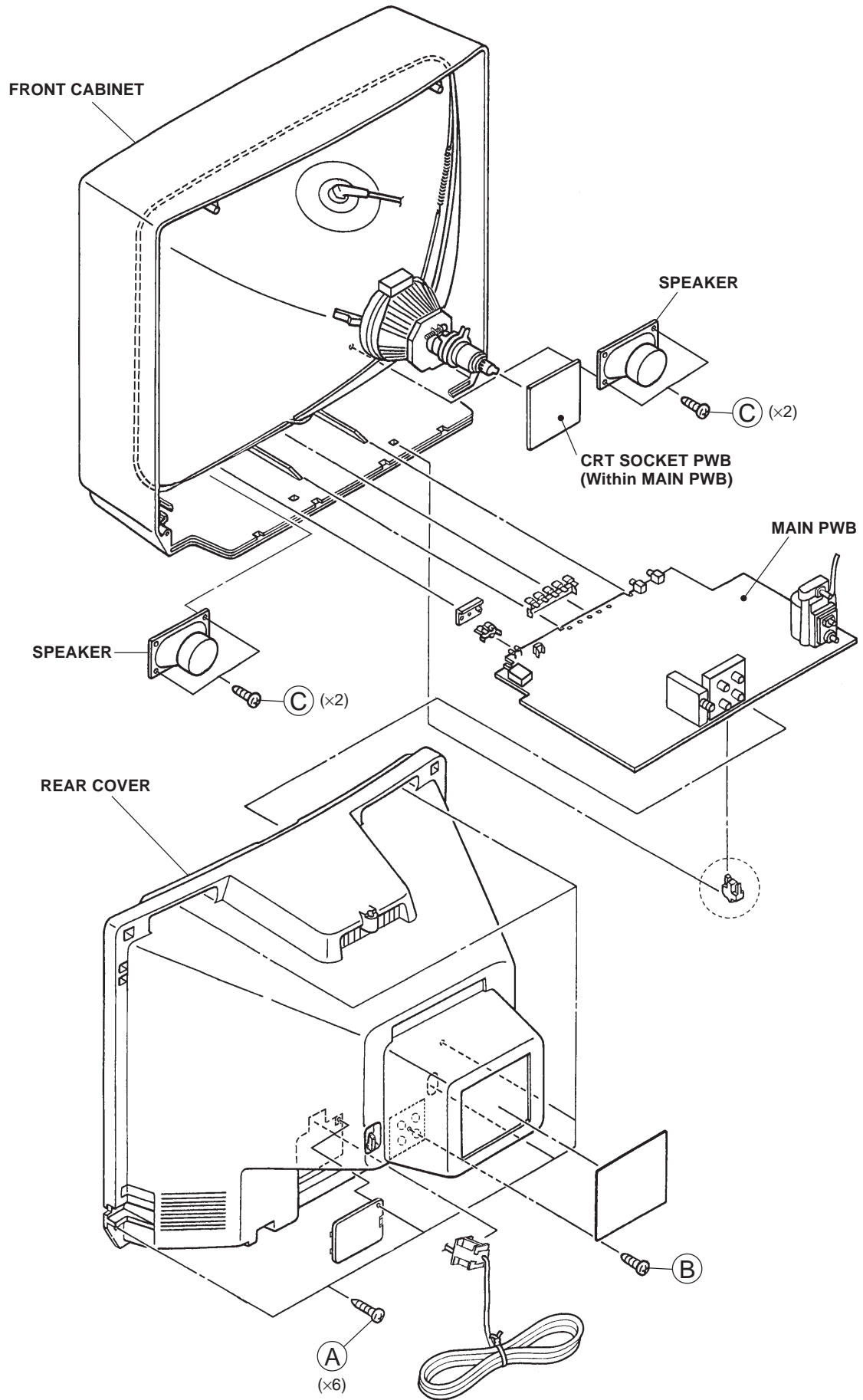

# REPLACEMENT OF MEMORY IC

## 1. MEMORY IC

This TV uses the following memory IC.

### Memory IC: IC1702 on MAIN PW Board

The memory IC memorizes data for correctly operating the video and deflection circuits. When replacing the memory IC, be sure to use the same type IC written with the initial values of data. In other words, use the specific IC listed in "PRINTED WIRING BOARD PARTS LIST". For its mounting location, refer to "ADJUSTMENT LOCATIONS".

## 2. PROCEDURE FOR REPLACING MEMORY IC

### (1) Power off

Switch the power off and unplug the power cord from the wall outlet.

### (2) Replacing the memory IC

Replace the memory IC with new one. Be sure to use the memory IC written with the initial data values.

### (3) Power on

Plug the power cord into the wall outlet and switch the power on.

### (4) Check and setting of SYSTEM CONSTANT SET:

- 1) Press the DISPLAY key and the PICTURE MODE key on the remote control unit simultaneously. The SERVICE MENU screen will be displayed. (See Fig. 1.)
- 2) In the SERVICE MENU, press the DISPLAY key and PICTURE MODE key simultaneously. Then, the SYSTEM CONSTANT SET screen will be displayed. (See Fig. 2.)
- 3) Check whether the setting values of the SYSTEM CONSTANT SET are the same as those indicated in Table 1. If the value is different, select the setting item with the MENU  $\nabla/\Delta$  key, and set the correct value with the MENU - / + key.
- 4) Press the DISPLAY key twice to return to the normal screen.

### (5) Receive channel setting

Refer to the **OPERATING INSTRUCTIONS** and set the receive channels (channels preset).

### (6) User setting

Check the user setting values in Table 2, and if setting value is different, set the correct value.  
For setting, refer to the **OPERATING INSTRUCTIONS**.

### (7) Setting of SERVICE MENU

Verify the setting for each setting item in the SERVICE MENU. (See Table 3.) If readjustment is necessary, perform adjustment referring to "SERVICE ADJUSTMENTS".

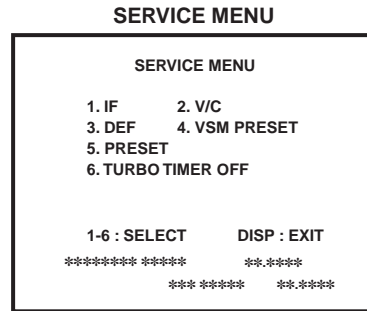

Fig. 1

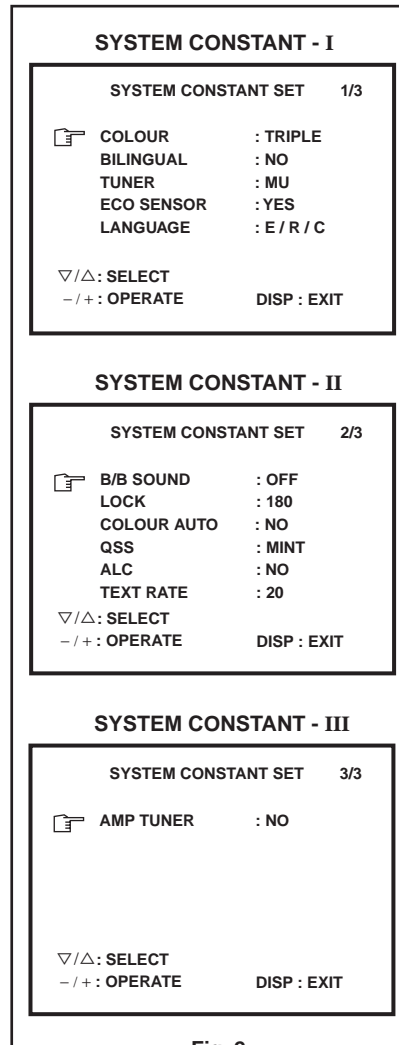
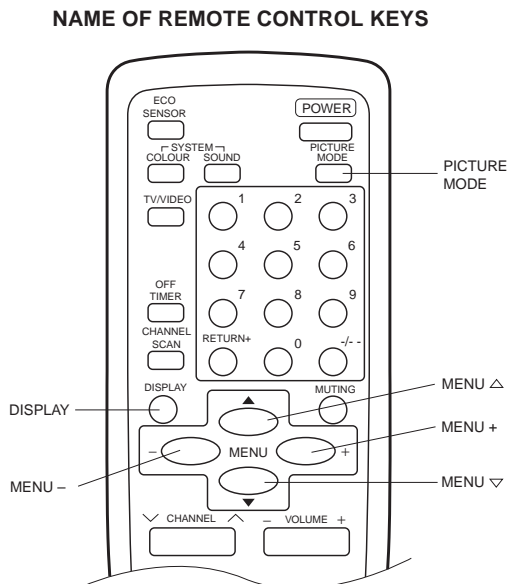

Fig. 2

## SETTING OF SYSTEM CONSTANT SET

Table 1

Setting item	Setting contents	Setting value
COLOUR	<input type="checkbox"/> → MULTI. → TRIPLE → PAL <input type="checkbox"/>	TRIPLE
BILINGUAL	<input type="checkbox"/> → YES → NO <input type="checkbox"/>	NO
TUNER	<input type="checkbox"/> → MU → MA <input type="checkbox"/>	MU
ECO SENSOR	<input type="checkbox"/> → YES → NO <input type="checkbox"/>	YES
LANGUAGE	<input type="checkbox"/> → E/R/C/U → E/R/C → E/R/U → E/C <input type="checkbox"/>	E/R/C
B/B SOUND	<input type="checkbox"/> → ON → OFF <input type="checkbox"/>	OFF
LOCK	YES ↔ 10 ↔ 20 ↔ ... ↔ 230 ↔ 250 ↔ 240 ←	180
COLOUR AUTO	<input type="checkbox"/> → YES → NO <input type="checkbox"/>	NO
QSS	<input type="checkbox"/> → MINT → MQSS <input type="checkbox"/>	MINT
ALC	<input type="checkbox"/> → YES → NO <input type="checkbox"/>	NO
TEXT RATE	10 ↔ 20 ↔ 40 ↔ 80	20
AMP TUNER	<input type="checkbox"/> → YES → NO <input type="checkbox"/>	NO

## USER SETTING VALUES

Table 2

Setting item	Setting value	Setting item	Setting value
SUB POWER	ON	PICTURE MODE (VSM)	BRIGHT
CHANNEL POSITION	1 POSITION	VNR	OFF
CHANNEL PRESET	Refer to OPERATING INSTRUCTION	OFF TIMER	OFF
		LANGUAGE	ENGLISH
VOLUME	Appropriate sound volume	AUTO SHUTOFF	OFF
TV/VIDEO	TV	ECO SENSOR	OFF
ON SCREEN DISPLAY	POSITION NUMBER DISPLAY	BLUE BACK	OFF
COLOUR SYSTEM	AUTO PAL	ON TIMER	PR1 0:00
SOUND SYSTEM	B / G	CHILD LOCK	OFF

SERVICE MENU SETTING ITEMS

Table 3

Service menu	Setting item	Service menu	Setting item
1. IF	1. VCO 2. DELAY POINT	5. PRESET	1. C-TRAP FIX 2. SHARP PEAK 3. ABL 4. GAMMA 5. Y.DELAY TIME 6. BLACK EXP START 7. C-BPF 8. CW/SCP 9. V.IF DET. LEVEL 10. S.IF DET. LEVEL 11. IF AGC MIN. 12. V.IF AGC 13. V.IF PMOD 14. S.IF BPF BW ADJUST 15. S.IF TRAP FO ADJUST 16. S.IF TRAP FO ADJUST 2 17. S.IF-TRAP 18. S.IF-BPF 19. VNR 20. RGB LIM. 21. RGB LIMIT LEVEL 22. S.IF SW 23. TEXT H. POSITION 24. READ DATA
2. V / C	1. CUTOFF(R/G/B) 2. DRIVE(R/B) 3. BRIGHT 4. CONT. 5. COLOUR (P / S/ N3 / N4) 6. TINT (N3 / N4) 7. SECAM BL ADJ 8. SHARP (TV / VIDEO) ← <b>Do not adjust.</b>		
3. DEF	1. VER. POSITION 2. HOR. POSITION 3. VER. HEIGHT 4. VER. LINEARITY 5. VER. SCURVE 6. HOR. VCO ADJUST ← <b>Do not adjust.</b>		
4. VSM PRESET (BRIGHT/STD/SOFT)	TINT COLOUR BRIGHT CONT. SHARP <b>Do not adjust.</b>		
		6. TURBO TIMER	ON/OFF Should be set to OFF. (When you turn the TV power off, the Turbo Timer is automatically set to OFF.)



# REPLACEMENT OF CHIP COMPONENT

## ■ CAUTIONS

1. Avoid heating for more than 3 seconds.
2. Do not rub the electrodes and the resist parts of the pattern.
3. When removing a chip part, melt the solder adequately.
4. Do not reuse a chip part after removing it.

## ■ SOLDERING IRON

1. Use a high insulation soldering iron with a thin pointed end of it.
2. A 30W soldering iron is recommended for easily removing parts.

## ■ REPLACEMENT STEPS

### 1. How to remove Chip parts

#### ● Resistors, capacitors, etc.

- (1) As shown in the figure, while pushing the chip part with tweezers, alternately melt the solder at its each end.

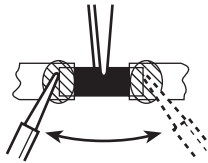

- (2) Shift the chip part with tweezers and remove it.

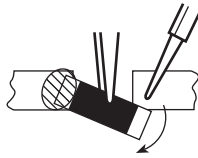

#### ● Transistors, diodes, variable resistors, etc.

- (1) Apply extra solder to each lead.



- (2) As shown in the figure, while pushing the chip part with tweezers, alternately melt the solder at its each lead. Then, shift and remove the chip part.



*Note : After removing the part, remove remaining solder from the pattern.*

### 2. How to install Chip parts

#### ● Resistors, capacitors, etc.

- (1) Apply solder to the pattern as indicated in the figure.

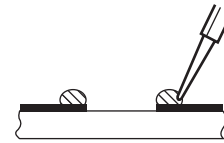

- (2) Grasp the chip part with tweezers and place it on the solder. Then heat and melt the solder at both ends of the chip part.

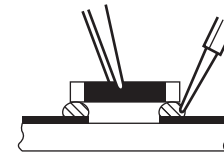

#### ● Transistors, diodes, variable resistors, etc.

- (1) Apply solder to the pattern as indicated in the figure.
- (2) Grasp the chip part with tweezers and place it on the solder.
- (3) First solder lead **A** as indicated in the figure.

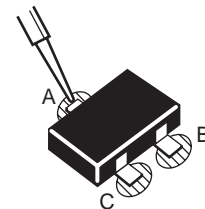

- (4) Then solder leads **B** and **C**.

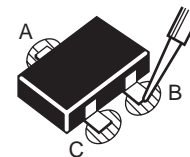

# SERVICE ADJUSTMENTS

## BEFORE STARTING SERVICE ADJUSTMENT

1. There are 2 ways for adjusting this TV: One is with the REMOTE CONTROL UNIT and the other is the conventional method using adjustment parts and components.
2. The setting (adjustment) using the REMOTE CONTROL UNIT is made on the basis of the initial setting values. The setting values which adjust the screen to the optimum condition can be different from the initial setting values.
3. Make sure that connection is correctly made to AC power source.
4. Turn on the power of the TV and measuring instrument for warming up for at least 30 minutes before starting adjustment.
5. If the receive or input signal is not specified, use the most appropriate signal for adjustment.
6. Never touch parts (such as variable resistors, transformers and capacitors) not shown in the adjustment items of this service adjustment.

7. Preparation for adjustment (presetting):

Unless otherwise specified in the adjustment items, preset the following functions with the remote control unit.

Function	Setting value
PICTURE MODE (VSM)	BRIGHT
COLOUR/BRIGHT/CONT./SHARP	See "VSM Preset" on page 22.
VNR	OFF
OFF TIMER	OFF
ECO SENSOR	OFF
BLUE BACK	OFF

## MEASURING INSTRUMENT AND FIXTURES

1. DC voltmeter (or Digital voltmeter)
2. Oscilloscope
3. Signal generator (Pattern generator)  
[PAL / SECAM / NTSC]
4. Remote control unit

## ADJUSTMENT/CHECK ITEMS

Adjustment/Check item	Page
B1 POWER SUPPLY Check	14
FOCUS Adjustment	14
IF CIRCUIT Adjustment	14
V/C (VIDEO/CHROMA) CIRCUIT Adjustment	15
DEFLECTION CIRCUIT Adjustment	20
VSM PRESET Adjustment	22
PRESET Adjustment	23
PURITY, CONVERGENCE Adjustment	24

## BASIC OPERATION IN SERVICE MENU

### 1. TOOL OF SERVICE MENU OPERATION

Operate the SERVICE MENU with the remote control unit.

### 2. SERVICE MENU ITEMS

With the SERVICE MENU, various settings (adjustments) can be made, and they are broadly classified in the following items of settings:

- 1. IF ..... For entering/adjusting the setting values (adjustment values) of the IF circuit.
- 2. V/C ..... For entering/adjusting the setting values (adjustment values) of the VIDEO/CHROMA circuit.
- 3. DEF ..... For entering/adjusting the setting values (adjustment values) of the DEFLECTION circuit.
- 4. VSM PRESET ..... For setting the values of STANDARD, SOFT and BRIGHT. (Do not adjust the preset values.)  
(VSM: video status memory)
- 5. PRESET ..... For setting the values for VIDEO/CHROMA control. (Do not adjust the preset values.)
- 6. TURBO TIMER ..... For quick setting the values of TIMER COUNT — adjustable not only by minutes but also by second. If it is ON, the time in TIMER mode changes from 1 minute into 1 second temporarily. (Applicable to OFF TIMER, ON TIMER and AUTO SHUTOFF)

**Note:** When you turn the TV power off, the Turbo Timer is automatically set to OFF.

### 3. BASIC OPERATION IN SERVICE MENU

#### (1) How to enter SERVICE MENU

Press the DISPLAY key and the PICTURE MODE key on the remote control unit simultaneously.

The SERVICE MENU screen will be displayed. (See Fig. 1.)

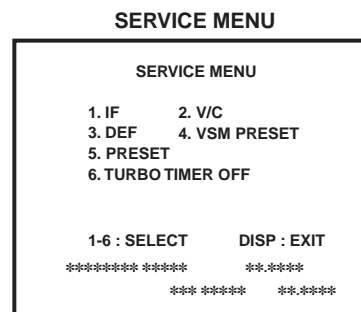

Fig. 1

#### (2) Selection of SUB MENU SCREEN

Press one of the keys 1 ~ 6 on the remote control unit, and select the SUB MENU SCREEN from the SERVICE MENU. (See Fig. 2 on the next page.)

SERVICE MENU → SUB MENU	<b>1. IF</b> <b>2. V / C</b> <b>3. DEF</b> <b>4. VSM PRESET</b> <b>5. PRESET</b> <b>6. TURBO TIMER</b>
-------------------------	---

#### (3) Method of Setting

\*Once the setting values are set, they are memorized automatically.

\*It must not adjust without inputting a signal.

##### 1) 1. IF

[1. VCO]

- (a) 1 Key ..... Select **1. IF**.
- (b) 1 Key ..... Select 1. VCO. (CW)
- (c) VCO(CW) . ..... Adjust VCO(CW) while watching the colour (yellow/blue) of the characters on the screen.  
For details, refer to the adjustment table.
- (d) DISPLAY Key ..... When this is pressed twice, you will return to the SERVICE MENU.

[2. DELAY POINT]

- (a) 1 Key ..... Select **1. IF**.
- (b) 2 Key ..... Select 2. DELAY POINT.
- (c) MENU - / + Key ..... Adjust the setting value.
- (d) DISPLAY Key ..... When this is pressed twice, you will return to the SERVICE MENU.

##### 2) 2. V/C, 3. DEF, 4. VSM PRESET and 5. PRESET

**Note:** Do not adjust "4. VSM PRESET" and "5. PRESET" unless you had changed its value by mistake.

- (a) 2 ~ 5 Keys ..... Select one from **2. V/C, 3. DEF, 4. VSM PRESET and 5. PRESET**.
- (b) MENU ▽/△ key ..... Select setting items.
- (c) MENU - / + Key ..... Adjust the setting values of the setting items.  
● Use the number keys on the remote control unit for setting of WHITE BALANCE and BLACK OFFSET. For the setting, refer to each item concerned.
- (d) DISPLAY Key ..... When this is pressed, you will return to the SERVICE MENU.

##### 3) 6. TURBO TIMER

- (a) 6 Key ..... Each time you press the key, ON/OFF state of TURBO TIMER changes.  
(Should be set to OFF.)

#### (4) Release of SERVICE MENU

After completing the setting, return to the SERVICE MENU by pressing the DISPLAY key, then again press the DISPLAY key to return to the normal screen.

SUB MENU SCREEN

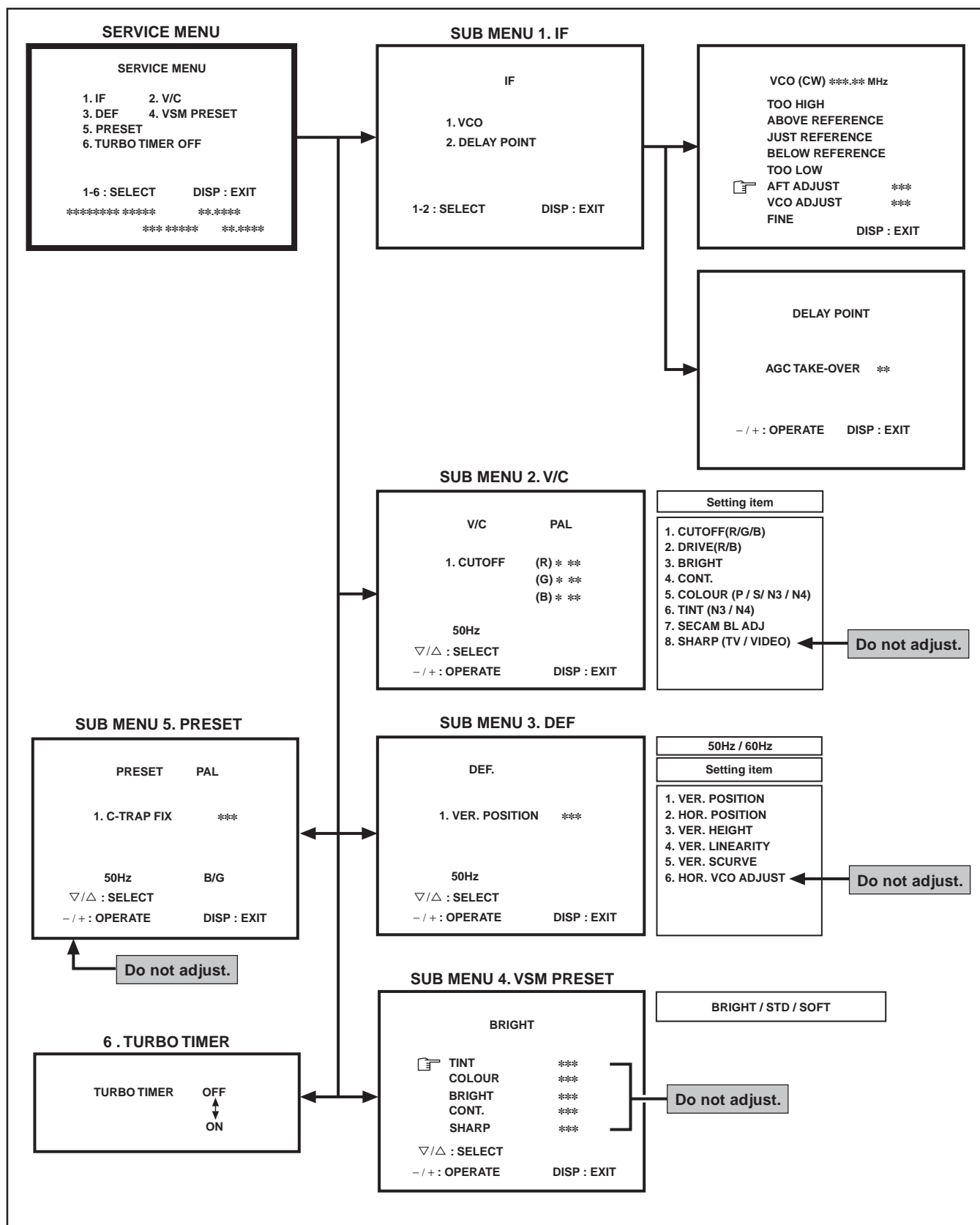
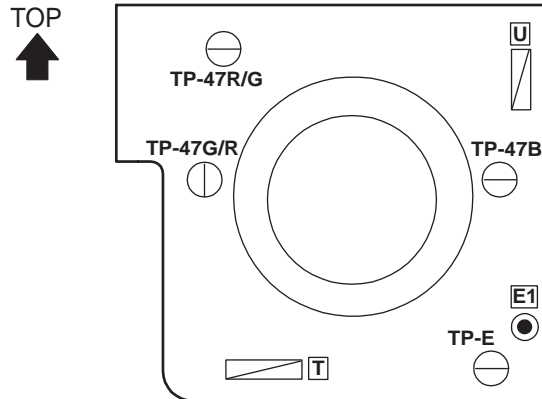

Fig. 2

# ADJUSTMENT LOCATIONS

## CRT SOCKET PWB (Within MAIN PWB) (SOLDER SIDE)



## MAIN PWB

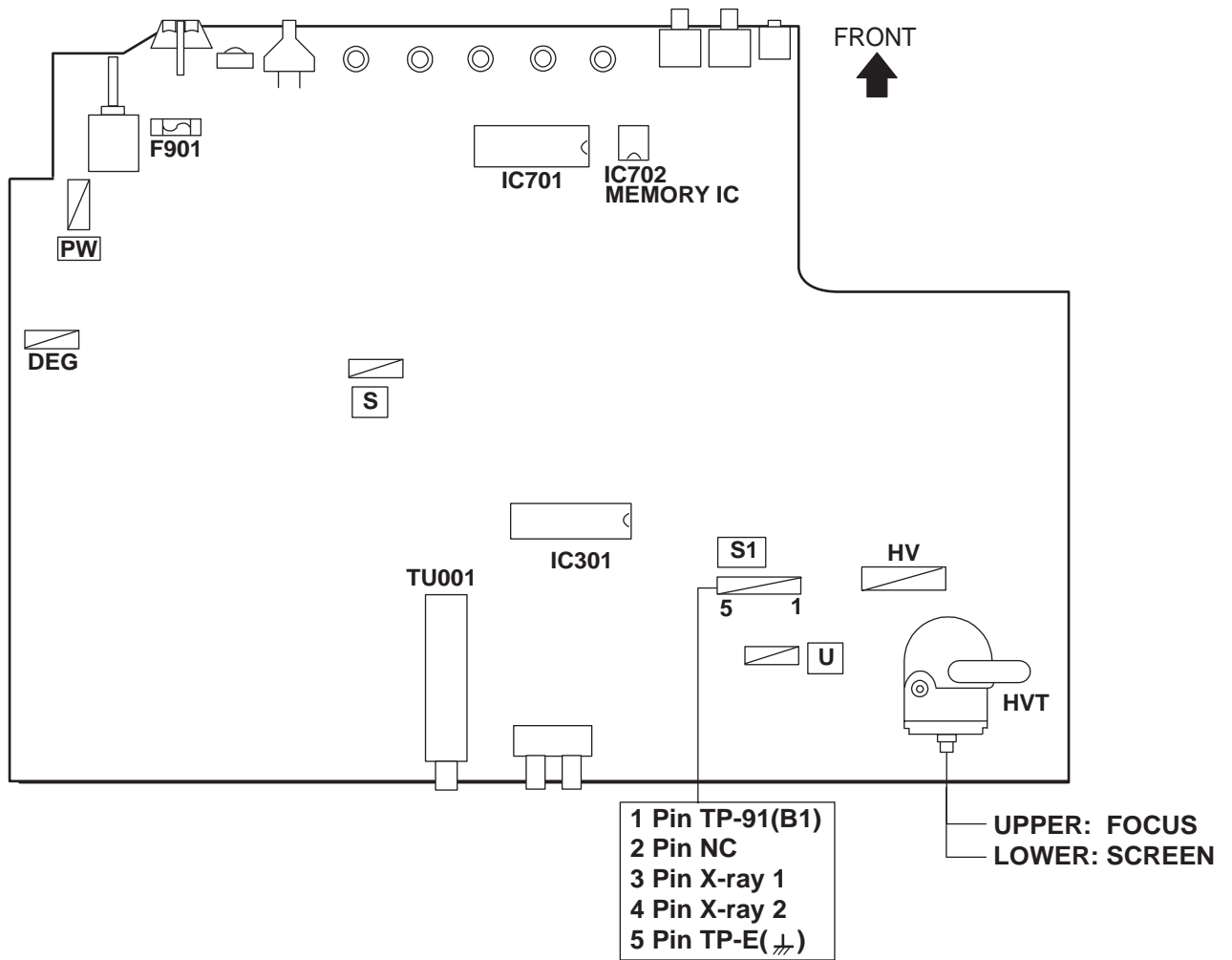

# ADJUSTMENTS

## B1 POWER SUPPLY

Item	Measuring instrument	Test point	Adjustment part	Description
Check of B1 POWER SUPPLY	<ul style="list-style-type: none"> <li>● Signal Generator</li> <li>● DC Voltmeter</li> </ul>	TP-91 (B1) TP-E (↗) [S1 connector]		<ol style="list-style-type: none"> <li>1. Receive a whole black signal.</li> <li>2. Connect a DC voltmeter between TP-91 (B1) and TP-E (↗) (between pins 1 and 5 of the connector S1).</li> <li>3. Make sure that the voltage is <b>DC114.5 ± 1.5V</b>.</li> </ol>

## FOCUS ADJUSTMENT

Item	Measuring instrument	Test point	Adjustment part	Description
Adjustment of FOCUS	Signal generator		FOCUS VR [In HVT]	<ol style="list-style-type: none"> <li>1. Receive a cross-hatch signal.</li> <li>2. While watching the screen, adjust the FOCUS VR to make the vertical and horizontal lines as fine and sharp as possible.</li> <li>3. Make sure that, when the screen is darkened, the lines remain in good focus.</li> </ol>

## IF CIRCUIT ADJUSTMENT

Item	Measuring instrument	Test point	Adjustment part	Description
Adjustment of VCO (CW)	Remote control unit		VCO (CW)	<ul style="list-style-type: none"> <li>● <b>Under normal conditions, no adjustment is required.</b></li> <li><b>Note: Do not adjust without inputting signal.</b></li> </ul> <ol style="list-style-type: none"> <li>1. Receive a colour bar signal.</li> <li>2. Select <b>1. IF</b> from the SERVICE MENU.</li> <li>3. Press the 1 key to select <b>1. VCO</b>.</li> <li>4. Select <b>VCO ADJUST</b> with the MENU ▾/△ key and make sure that the setup value shown in the screen is +00.</li> <li>5. Press the MENU – or + key until the colour of the characters "TOO HIGH" displayed on the screen changes from blue to <b>yellow</b>.</li> <li>6. Press the MENU – or + key until the colour of the characters "TOO LOW" displayed on the screen changes from blue to <b>yellow</b>. At this time, check that the value of <b>VCO ADJUST</b> on the screen is +00 or about +00.</li> <li>7. Select <b>AFT ADJUST</b> with the MENU ▾/△ key.</li> <li>8. Then, press the MENU – or + key until the colour of the characters "JUST REFERENCE" displayed on the screen changes from blue to <b>yellow</b>.</li> <li>9. Press the DISPLAY key three times to return to normal screen.</li> </ol>

VCO (CW) \*\*\*.\*\*\* MHz ← fv

TOO HIGH  
ABOVE REFERENCE  
JUST REFERENCE ← YELLOW  
BELOW REFERENCE  
TOO LOW

AFT ADJUST \*\*\*  
VCO ADJUST \*\*\*  
FINE ← **Do not adjust.**

DISP : EXIT

Item	Measuring instrument	Test point	Adjustment part	Description		
Adjustment of DELAY POINT	Remote control unit		DELAY POINT (AGC TAKE-OVER)	<ol style="list-style-type: none"> <li>1. Receive a black and white signal (colour off).</li> <li>2. Select <b>1. IF</b> from the SERVICE MENU.</li> <li>3. Select <b>2. DELAY POINT</b> by pressing the <b>2</b> key on the remote control.</li> <li>4. Adjust the MENU – or + key until video noise disappears.</li> <li>5. Press the DISPLAY key three times to return to the normal screen.</li> <li>6. Turn to other channels and make sure that there are no irregularities.</li> </ol>		
					<table border="1"> <thead> <tr> <th>Setting (Adjustment) Item</th> <th>Variable range</th> <th>Initial setting value</th> </tr> </thead> <tbody> <tr> <td>DELAY POINT (AGC TAKE-OVER)</td> <td>0 ~ 127</td> <td>43</td> </tr> </tbody> </table>	Setting (Adjustment) Item
Setting (Adjustment) Item	Variable range	Initial setting value				
DELAY POINT (AGC TAKE-OVER)	0 ~ 127	43				

## V/C (VIDEO/CHROMA) CIRCUIT ADJUSTMENT

The setting (adjustment) using the remote control unit is made on the basis of the initial setting values.  
 The setting values which adjust the screen to the optimum condition can be different from the initial setting values.

- Do not change the initial setting values of the setting (adjustment) items not listed in "ADJUSTMENT".

### [SUB MENU 2. V/C]

Setting item	Colour system	Variable range	Initial setting value			
			PAL	SECAM	NTSC 3.58	NTSC 4.43
1. CUT OFF (R / G / B)		-128 ~ +127	-50	←	←	←
2. DRIVE (R / B)		-64 ~ +63	0	←	←	←
3. BRIGHT		-128 ~ +127	0	←	←	←
4. CONT.		-64 ~ +63	0	←	←	←
5. COLOUR (P / S / N3 / N4)		-64 ~ +63	0	←	←	←
6. TINT (N3 / N4)	TV / VIDEO	-64 ~ +63	—	—	0 / 0	0 / 0
7. SECAM BL ADJUST		-32 ~ +31	0	←	←	←
8. SHARP	TV / VIDEO	-32 ~ +31	-5 / +15	←	←	←

 : Do not adjust.

Item	Measuring instrument	Test point	Adjustment part	Description										
<p><b>Adjustment of WHITE BALANCE (Low light)</b></p>	<ul style="list-style-type: none"> <li>● Signal generator</li> <li>● Remote control unit</li> </ul>		<p><b>1. CUTOFF (R)</b>  <b>CUTOFF (G)</b>  <b>CUTOFF (B)</b></p> <p><b>SCREEN VR</b>  <b>(In HVT)</b></p>	<ol style="list-style-type: none"> <li>1. Receive a black and white signal (colour off).</li> <li>2. Select <b>2. V/C</b> from the SERVICE MENU.</li> <li>3. Select <b>1. CUTOFF (R), (G) and (B)</b> with the MENU <math>\nabla/\Delta</math> key, and set each value to initial setting value with <b>4 ~ 9</b> keys on the remote control unit.</li> <li>4. Press the <b>1</b> key on the remote control unit to produce a single horizontal line.</li> <li>5. Turn the SCREEN VR fully counterclockwise, then slowly turn it clockwise to where a red, blue, or green colour is faintly visible.</li> <li>6. Use keys <b>4 ~ 9</b> on the remote control unit and adjust the other 2 colours to where the single horizontal line appears white.</li> <li>7. Turn the SCREEN VR to where the single horizontal line glows faintly.</li> <li>8. Press the <b>2</b> key to return to <b>1. CUTOFF</b> screen.</li> <li>9. Press the DISPLAY key twice to return to the normal screen.</li> </ol> <table border="1" data-bbox="797 772 1398 989" style="width: 100%; border-collapse: collapse; margin-top: 20px;"> <thead> <tr> <th style="width: 30%;">Setting (Adjustment) item</th> <th style="width: 30%;">Variable range</th> <th style="width: 40%;">Initial setting value</th> </tr> </thead> <tbody> <tr> <td rowspan="3">1. CUT OFF</td> <td>R</td> <td>-128 ~ +127</td> </tr> <tr> <td>G</td> <td>-128 ~ +127</td> </tr> <tr> <td>B</td> <td>-128 ~ +127</td> </tr> </tbody> </table>	Setting (Adjustment) item	Variable range	Initial setting value	1. CUT OFF	R	-128 ~ +127	G	-128 ~ +127	B	-128 ~ +127
Setting (Adjustment) item	Variable range	Initial setting value												
1. CUT OFF	R	-128 ~ +127												
	G	-128 ~ +127												
	B	-128 ~ +127												
<p><b>Adjustment of WHITE BALANCE (High light)</b></p>	<ul style="list-style-type: none"> <li>● Signal generator</li> <li>● Remote control unit</li> </ul>		<p><b>2. DRIVE (R)</b>  <b>DRIVE (B)</b></p>	<ol style="list-style-type: none"> <li>1. Receive a black and white signal (colour off).</li> <li>2. Select <b>2. V/C</b> from the SERVICE MENU.</li> <li>3. Select <b>2. DRIVE (R) / (B)</b> with MENU <math>\nabla/\Delta</math> key, and set each value to initial setting value with <b>4</b> and <b>7</b> keys, or <b>6</b> and <b>9</b> keys on the remote control unit.</li> <li>4. Use the keys <b>4</b> and <b>7</b> or <b>6</b> and <b>9</b> to produce a white screen.</li> <li>5. Press the DISPLAY key twice to return to the normal screen.</li> </ol> <table border="1" data-bbox="797 1566 1398 1740" style="width: 100%; border-collapse: collapse; margin-top: 20px;"> <thead> <tr> <th style="width: 30%;">Setting (Adjustment) item</th> <th style="width: 30%;">Variable range</th> <th style="width: 40%;">Initial setting value</th> </tr> </thead> <tbody> <tr> <td rowspan="2">2. DRIVE</td> <td>R</td> <td>-64 ~ +63</td> </tr> <tr> <td>B</td> <td>-64 ~ +63</td> </tr> </tbody> </table>	Setting (Adjustment) item	Variable range	Initial setting value	2. DRIVE	R	-64 ~ +63	B	-64 ~ +63		
Setting (Adjustment) item	Variable range	Initial setting value												
2. DRIVE	R	-64 ~ +63												
	B	-64 ~ +63												

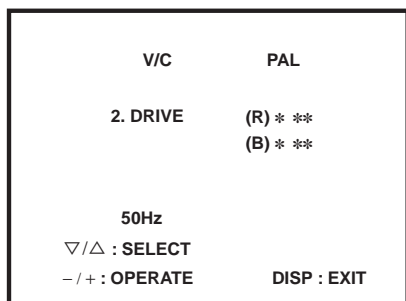
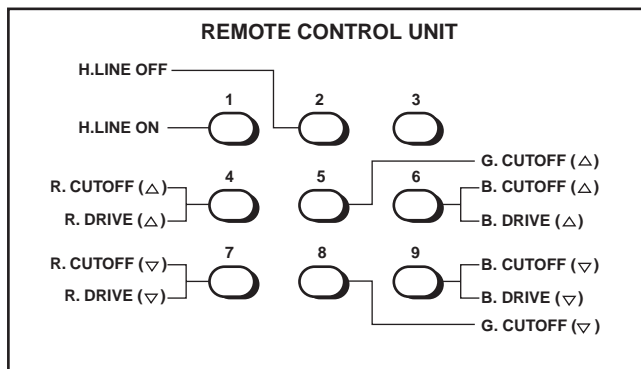
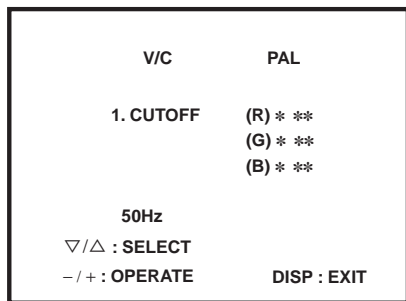



Item	Measuring instrument	Test point	Adjustment part	Description
Adjustment of SUB BRIGHT	Remote control unit		3. BRIGHT	<ol style="list-style-type: none"> <li>1. Receive any broadcast.</li> <li>2. Select <b>2. V/C</b> from the SERVICE MENU.</li> <li>3. Select <b>3. BRIGHT</b> with the MENU <math>\nabla/\Delta</math> key.</li> <li>4. Set the initial setting value with the MENU – or + key.</li> <li>5. If the brightness is not the best with the initial set value, make fine adjustment until you get the best brightness.</li> <li>6. Press the DISPLAY key twice to return to the normal screen.</li> </ol>
Adjustment of SUB CONT.	Remote control unit		4. CONT.	<ol style="list-style-type: none"> <li>1. Receive any broadcast.</li> <li>2. Select <b>2. V/C</b> from the SERVICE MENU.</li> <li>3. Select <b>4. CONT.</b> with the MENU <math>\nabla/\Delta</math> key.</li> <li>4. Set the initial setting value with the MENU – or + key.</li> <li>5. If the contrast is not the best with the initial set value, make fine adjustment until you get the best contrast.</li> <li>6. Press the DISPLAY key twice to return to the normal screen.</li> </ol>
Adjustment of SUB COLOUR-I	Remote control unit		5. COLOR	<b>[Method of adjustment without measuring instrument]</b>
			PAL COLOUR	<b>(PAL COLOUR)</b> <ol style="list-style-type: none"> <li>1. Receive a PAL broadcast.</li> <li>2. Select <b>2. V/C</b> from the SERVICE MENU.</li> <li>3. Select <b>5. COLOUR</b> with the MENU <math>\nabla/\Delta</math> key.</li> <li>4. Set the initial setting value for PAL COLOUR with the MENU – or + key.</li> <li>5. If the colour is not the best with the initial set value, make fine adjustment until you get the best colour.</li> <li>6. Press the DISPLAY key twice to return to the normal screen.</li> </ol>
			SECAM COLOUR	<b>(SECAM COLOUR)</b> <ol style="list-style-type: none"> <li>1. Receive a SECAM broadcast.</li> <li>2. Make fine adjustment of SECAM COLOUR in the same way as for "PAL COLOUR".</li> </ol>
			NTSC 3.58 COLOUR	<b>(NTSC 3.58 COLOUR)</b> <ol style="list-style-type: none"> <li>1. Receive a NTSC 3.58MHz broadcast.</li> <li>2. Make similar fine adjustment of NTSC 3.58 COLOUR in the same way as for "PAL COLOUR".</li> </ol>
				<b>(NTSC 4.43 COLOUR)</b> When adjustment is done for NTSC 3.58 COLOUR, appropriate values are automatically set for NTSC 4.43 COLOUR.

Item	Measuring instrument	Test point	Adjustment part	Description
Adjustment of SUB COLOUR-II	<ul style="list-style-type: none"> <li>● Signal generator</li> <li>● Oscilloscope</li> <li>● Remote control unit</li> </ul>	TP-47G/R TP-E (↗) [CRT SOCKET PWB]	<b>5. COLOUR</b>	<b>[Method of adjustment using measuring instrument]</b>
			PAL COLOUR	<b>(PAL COLOUR)</b> 1. Receive a PAL full field colour bar signal (75% white). 2. Select <b>2. V/C</b> from the SERVICE MENU. 3. Select <b>5. COLOUR</b> with the MENU ▽/△ key. 4. Set the initial setting value of PAL COLOUR with the MENU – or + key. 5. Connect the oscilloscope between TP-47G/R and TP-E. 6. Adjust PAL COLOUR to set the value <b>(A)</b> in the figure to <b>+12V (W &amp; G)</b> .
			SECAM COLOUR	<b>(SECAM COLOUR)</b> 1. Receive a SECAM full field colour bar signal (75% white). 2. Set the initial setting value of SECAM COLOUR with the MENU – or + key. 3. Adjust SECAM COLOUR to set the value <b>(A)</b> in the figure to <b>+9V (W &amp; G)</b> .
			NTSC 3.58 COLOUR	<b>(NTSC 3.58 COLOUR)</b> 1. Receive a NTSC 3.58 full field colour bar signal (75% white). 2. Set the initial setting value of NTSC 3.58 COLOUR with the MENU – or + key. 3. Adjust NTSC 3.58 COLOUR to set the value <b>(A)</b> in the figure to <b>+7V (W &amp; G)</b> .  <b>(NTSC 4.43 COLOUR)</b> When adjustment is done for NTSC 3.58 COLOUR, appropriate values are automatically set for NTSC 4.43 COLOUR.
Adjustment of SUB TINT-I	Remote control unit		<b>6. TINT</b>	<b>[Method of adjustment without measuring instrument]</b>
			NTSC 3.58 TINT	<b>(NTSC 3.58 TINT)</b> 1. Receive a NTSC 3.58 colour bar signal (full field colour bar 75% white). 2. Select <b>2. V/C</b> from the SERVICE MENU. 3. Select <b>6. TINT</b> with the MENU ▽/△ key. 4. Set the initial setting value of NTSC 3.58 with the MENU – or + key. 5. If you cannot get the best tint with the initial setting value, make fine adjustment until you get the best tint. 6. Press the DISPLAY key twice to return to the normal screen.
				<b>(NTSC 4.43 COLOUR)</b> When adjustment is done for NTSC 3.58 TINT, appropriate values are automatically set for NTSC 4.43 TINT.

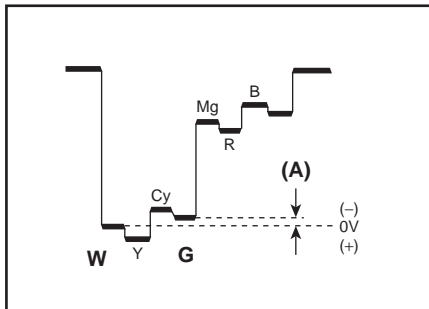

Item	Measuring instrument	Test point	Adjustment part	Description
Adjustment of SUB TINT-II	<ul style="list-style-type: none"> <li>● Signal generator</li> <li>● Oscilloscope</li> <li>● Remote control unit</li> </ul>	TP-47G/R TP-E (↕) [CRT SOCKET PWB]	6. TINT	[Method of adjustment using measuring instrument]
			NTSC 3.58 TINT	<p><b>(NTSC 3.58 TINT)</b></p> <ol style="list-style-type: none"> <li>1. Receive a NTSC 3.58 colour bar signal (full field colour bar 75% white).</li> <li>2. Select <b>2. V/C</b> from the SERVICE MENU.</li> <li>3. Select <b>6. TINT</b> with the MENU a key.</li> <li>4. Set the initial setting value of NTSC 3.58 with the MENU - or + key.</li> <li>5. Connect the oscilloscope between TP-47G/R and TP-E.</li> <li>6. Adjust NTSC 3.58 TINT to set the value <b>(B)</b> in the figure to <b>+7V (W &amp; Cy)</b>.</li> <li>7. Press the DISPLAY key twice to return to the normal screen.</li> </ol>
				<p><b>(NTSC 4.43 TINT)</b></p> When adjustment is done for NTSC 3.58 TINT, appropriate values are automatically set for NTSC 4.43 TINT.
Adjustment of BLACK OFFSET (SECAM)	Remote control unit			[Method of adjustment without measuring instrument]
			7. SECAM BL ADJUST	<ol style="list-style-type: none"> <li>1. Receive a SECAM HALF COLOUR BAR signal (210.25MHz).</li> <li>2. Select <b>2. V/C</b> from the SERVICE MENU.</li> <li>3. Select <b>7. SECAM BL ADJUST</b> with the MENU a key.</li> <li>4. Set the initial setting value the MENU - or + key.</li> <li>5. While alternately pressing keys <b>1</b> (Black &amp; White ON) and <b>2</b> (Black &amp; White OFF), make sure that there is no colour on the black &amp; white screen.</li> <li>6. If the black &amp; white screen is not the best with the initial setting value, make fine adjustment until you get the best black &amp; white screen.</li> <li>7. Press the DISPLAY key twice to return to the normal screen.</li> </ol>

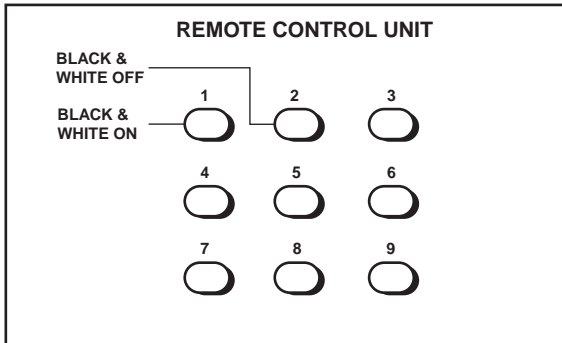
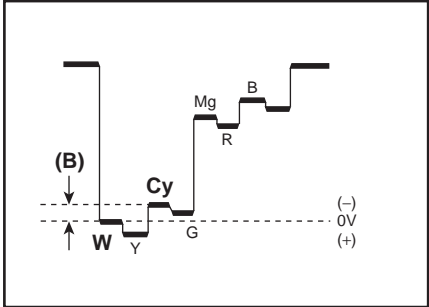

## DEFLECTION CIRCUIT ADJUSTMENT

- There are 2 modes of adjustment (initial setting value) — 50Hz mode and 60Hz mode — depending upon the kind of signals (vertical frequency 50Hz / 60Hz).
- When adjusted in 50Hz mode, 60Hz mode will be automatically set.

The setting (adjustment) using the remote control unit is made on the basis of the initial setting values.  
The setting values which adjust the screen to the optimum condition can be different from the initial setting values.

### [SUB MENU 4. DEF]

Setting item	Adjustment name	Variable range	Initial setting value	
			50Hz	60Hz
1. VER. POSITION	Vertical center	-4 ~ +3	-1	-3
2. HOR. POSITION	Horizontal center	-16 ~ +15	+3	+3
3. VER. HEIGHT	Vertical height	-64 ~ +63	-35	+1
4. VER. LINEARITY	Vertical linearity	-32 ~ +31	+15	-1
5. VER. SCURVE	Vertical scurve	-32 ~ +31	-32	0
6. HOR. VCO ADJUST	Horizontal VCO	-64 ~ +63	0	0

: Do not adjust.

Item	Measuring instrument	Test point	Adjustment part	Description
Adjustment of V-HEIGHT & V-POSITION	<ul style="list-style-type: none"> <li>● Signal generator</li> <li>● Remote control unit</li> </ul>		1. VER. POSITION 3. VER. HEIGHT	<p>[ fv : 50Hz mode]</p> <ol style="list-style-type: none"> <li>1. Receive a cross-hatch signal.</li> <li>2. Select <b>3. DEF</b> from the SERVICE MENU.</li> <li>3. Select <b>1. VER. POSITION</b> with the MENU <math>\nabla/\Delta</math> key.</li> <li>4. Set the initial setting value of <b>1. VER. POSITION</b> with the MENU - / + key.</li> <li>5. Adjust VER. POSITION to make <math>V = V'</math>.</li> <li>6. Select <b>3. VER. HEIGHT</b> with the MENU <math>\nabla/\Delta</math> key.</li> <li>7. Set the initial setting value of <b>3. VER. HEIGHT</b> with the MENU - / + key.</li> <li>8. Adjust VER. HEIGHT and make the vertical screen size 92% of the picture size with the MENU - / + key.</li> </ol> <p>(to be continued)</p>

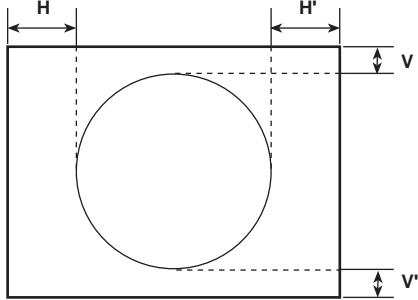
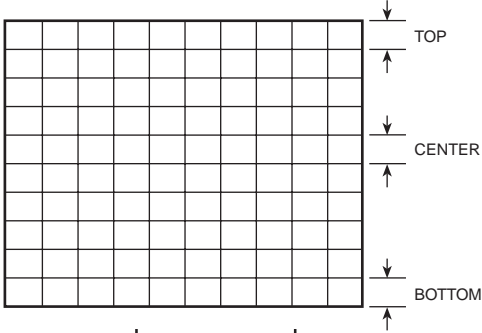
Item	Measuring instrument	Test point	Adjustment part	Description
<p><b>Adjustment of H-POSITION</b></p>			<p><b>2. HOR. POSITION</b></p>	<p>9. Receive a circle pattern signal.            10. Select <b>2. HOR. POSITION</b> with the MENU <math>\nabla/\Delta</math> key.            11. Set the initial setting value of <b>2. HOR. POSITION</b> with the MENU <math>-/+</math> key.            12. Adjust HOR. POSITION to make <math>H = H'</math> with the MENU <math>-/+</math> key.</p> 
<p><b>Adjustment of V-LINEARITY &amp; V-SCURVE</b></p>			<p><b>4. VER. LINEARITY</b>  <b>5. VER. SCURVE</b></p>	<ul style="list-style-type: none"> <li>● <b>When the vertical linearity has been deteriorated remarkably, perform the following steps.</b></li> </ul> <p>13. Receive a cross-hatch signal.            14. Select <b>4. VER. LINEARITY</b> with the MENU <math>\nabla/\Delta</math> key.            15. Set the initial setting value of <b>4. VER. LINEARITY</b> with the MENU <math>-/+</math> key.            16. Select <b>5. VER. SCURVE</b> with the MENU <math>\nabla/\Delta</math> key.            17. Set the initial setting value of <b>5. VER. SCURVE</b> with the MENU <math>-/+</math> key.            18. Adjust VER. LINEARITY and VER. SCURVE so that the spaces of each line on TOP, CENTER and BOTTOM become uniform.</p> 
				<p>19. Make sure that the adjustment is properly done on the screen of 60Hz mode.            20. Press the DISPLAY key twice to return to the normal screen.</p> <p><b>[NOTE]</b></p> <ul style="list-style-type: none"> <li>● When adjust in 60Hz mode, only 60Hz mode is adjust.</li> </ul>

**VSM PRESET ADJUSTMENT**

Item	Measuring instrument	Test point	Adjustment part	Description																								
<p><b>Setting of VSM PRESET</b></p>	<p>Remote control unit</p>		<p>TINT COLOUR BRIGHT CONT. SHARP</p>	<p>(VSM PRESET)</p> <ol style="list-style-type: none"> <li>1. Select <b>4. VSM PRESET</b> from the SERVICE MENU.</li> <li>2. Select BRIGHT with the PICTURE MODE key.</li> <li>3. Adjust the MENU ▽/△ key and MENU – or + key to reset the set values of <b>TINT ~ SHARP</b> to the values shown in the table.</li> <li>4. Respectively select the VSM PRESET mode for SOFT and STANDARD, and make similar adjustment as in 3 above.</li> <li>5. Press the DISPLAY key twice to return to the normal screen.</li> </ol> <p><b>[Setting Values for SUB MENU 4. VSM PRESET]</b></p> <table border="1" data-bbox="781 632 1382 1052"> <thead> <tr> <th data-bbox="781 632 1005 743">VSM preset mode VSM Setting item</th> <th data-bbox="1005 632 1130 743">BRIGHT</th> <th data-bbox="1130 632 1271 743">STANDARD</th> <th data-bbox="1271 632 1382 743">SOFT</th> </tr> </thead> <tbody> <tr> <td data-bbox="781 743 1005 810">TINT SETTING VALUE</td> <td data-bbox="1005 743 1130 810">+15</td> <td data-bbox="1130 743 1271 810">←</td> <td data-bbox="1271 743 1382 810">←</td> </tr> <tr> <td data-bbox="781 810 1005 869">COLOUR SETTING VALUE</td> <td data-bbox="1005 810 1130 869">+15</td> <td data-bbox="1130 810 1271 869">←</td> <td data-bbox="1271 810 1382 869">←</td> </tr> <tr> <td data-bbox="781 869 1005 930">BRIGHT SETTING VALUE</td> <td data-bbox="1005 869 1130 930">+15</td> <td data-bbox="1130 869 1271 930">←</td> <td data-bbox="1271 869 1382 930">←</td> </tr> <tr> <td data-bbox="781 930 1005 991">CONT. SETTING VALUE</td> <td data-bbox="1005 930 1130 991">+30</td> <td data-bbox="1130 930 1271 991">+15</td> <td data-bbox="1271 930 1382 991">+11</td> </tr> <tr> <td data-bbox="781 991 1005 1052">SHARP SETTING VALUE</td> <td data-bbox="1005 991 1130 1052">+15</td> <td data-bbox="1130 991 1271 1052">+15</td> <td data-bbox="1271 991 1382 1052">+12</td> </tr> </tbody> </table> <p>■ : Do not adjust.</p>	VSM preset mode VSM Setting item	BRIGHT	STANDARD	SOFT	TINT SETTING VALUE	+15	←	←	COLOUR SETTING VALUE	+15	←	←	BRIGHT SETTING VALUE	+15	←	←	CONT. SETTING VALUE	+30	+15	+11	SHARP SETTING VALUE	+15	+15	+12
VSM preset mode VSM Setting item	BRIGHT	STANDARD	SOFT																									
TINT SETTING VALUE	+15	←	←																									
COLOUR SETTING VALUE	+15	←	←																									
BRIGHT SETTING VALUE	+15	←	←																									
CONT. SETTING VALUE	+30	+15	+11																									
SHARP SETTING VALUE	+15	+15	+12																									

**SUB MENU 4. VSM PRESET**

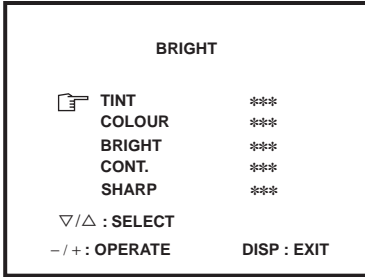

## PRESET ADJUSTMENT

- No adjustment is necessary.
- Adjust only when you had changed the value by miss operation.

## [SUB MENU 5. PRESET]

Colour system		Initial setting value			
		PAL	SECAM	NTSC 3.58	NTSC 4.43
1. C-TRAP FIX		1	←	←	←
2. SHARP PEAK		0	←	←	←
3. ABL		1	←	←	←
4. GAMMA		0	←	←	←
5. Y.DELAY TIME	TV	0	2	2	3
	VIDEO	0	2	0	2
6. BLACK EXP START		3	←	←	←
7. C-BPF	TV	1	←	0	←
	VIDEO	1	←	←	←
8. CW/SCP		0	←	←	←
9. V.IF DET. LEVEL		0	←	←	←
11. IF AGC MIN.		0	←	←	←
12. V.IF AGC		0	←	←	←
13. V.IF PMOD		0	←	←	←
19. VNR		15	←	←	←
20. RGB LIM.		1	←	←	←
21. RGB LIMIT LEVEL		2	←	←	←
23. TEXT H. POSITION		-3	←	←	←
24. READ DATA		—	—	—	—

: Do not adjust.

TV RF system		Initial setting value			
		B/G	I	D/K	M
10. S.IF DET. LEVEL		0	←	←	←
14. S.IF BPF BW ADJUST		0	←	←	←
15. S.IF TRAP FO ADJUST		0	←	←	←
16. S.IF TRAP FO ADJUST 2		0	←	←	←
17. S.IF-TRAP		0	←	←	←
18. S.IF-BPF		0	←	←	1
22. S.IF SW		1	←	←	0

: Do not adjust.

**PURITY, CONVERGENCE****PURITY ADJUSTMENT**

1. Demagnetize CRT with the demagnetizer.
2. Loosen the retainer screw of the deflection yoke.
3. Remove the wedges. (Fig. 1.)
4. Input a green raster signal from the signal generator, and turn the screen to green raster.
5. Move the deflection yoke backward.
6. Bring the long lug of the purity magnets on the short lug and position them horizontally. (Fig. 2)
7. Adjust the gap between two lugs so that the green raster will come into the center of the screen. (Fig. 3)
8. Move the deflection yoke forward, and fix the position of the deflection yoke so that the whole screen will become green.
9. Insert the wedge to the top side of the deflection yoke so that it will not move.
10. Input a cross-hatch signal.
11. Verify that the screen is horizontal.
12. Input red and blue raster signals, and make sure that purity is properly adjusted.

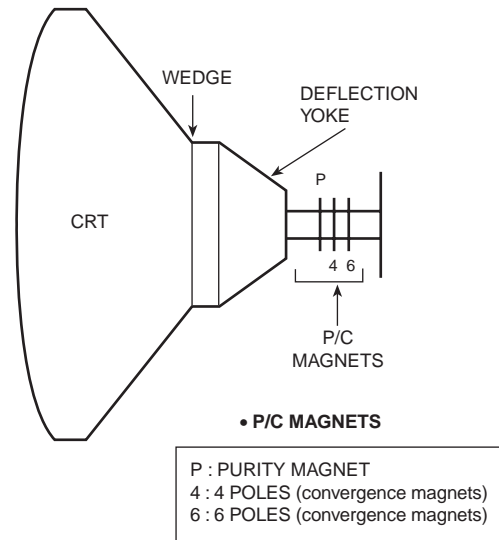
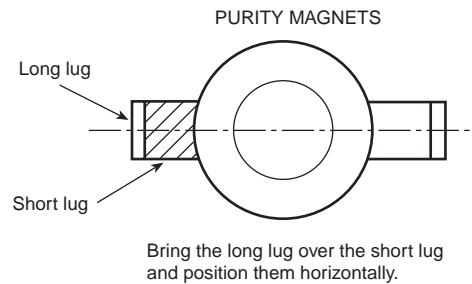
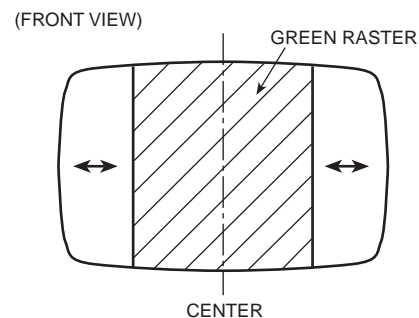
**Fig. 1****Fig. 2****Fig. 3**



**STATIC CONVERGENCE ADJUSTMENT**

1. Input a cross-hatch signal.
2. Using 4-pole convergence magnets, overlap the red and blue lines in the center of the screen (Fig. 1) to turn them to magenta (red/blue).
3. Using 6-pole convergence magnets, overlap the magenta (red/blue) and green lines in the center of the screen to turn them to white.
4. Repeat 2 and 3 above, and make best convergence.

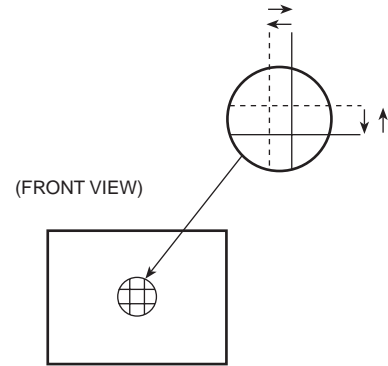

**Fig. 1**

**DYNAMIC CONVERGENCE ADJUSTMENT**

1. Move the deflection yoke up and down and overlap the lines in the center. (Fig. 2)
2. Move the deflection yoke left to right and overlap the lines in the periphery. (Fig. 3)
3. Repeat 1 and 2 above, and make best convergence.

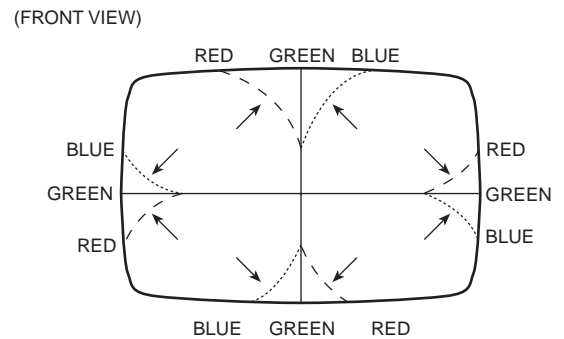

**Fig. 2**

- After adjustment, fix the wedge at the original position. Fasten the retainer screw of the deflection yoke. Fix the PC magnets with glue.

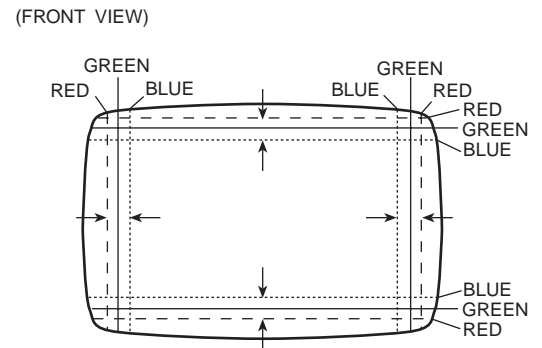

**Fig. 3**

## SELF-CHECK FUNCTIONS

### 1. Outline

This model has self-check functions given below. When an abnormality has been detected, the SUB POWER is turned off and the ON TIMER LED flashes to inform of the failure. An abnormality is detected by the signal input state of the control line connected to the microcomputer.

### 2. Self-check items

Check item	Details of detection	Method of detection	State of abnormality
Over-current protection	An over-current on the low B line is detected.	The main microcomputer detects the possible abnormality at 20-msec. intervals and judges the results in every 24 time. Of the 24 times, if NG is detected more than 13 times, it is judged that there is an abnormality.	When an abnormality has been detected, the SUB-POWER is turned off. While the SUB-POWER is being turned off, the POWER key on the remote control unit is not operational until the power cord is taken out and put in again.
CRT NECK protection	Operation of CRT NECK protection circuit	DITTO	DITTO

### 3. Self-check indicating function

When an abnormality has been detected at about 3 seconds after the power is turned on, the SUB POWER is turned off immediately and the ON TIMER LED flashes.

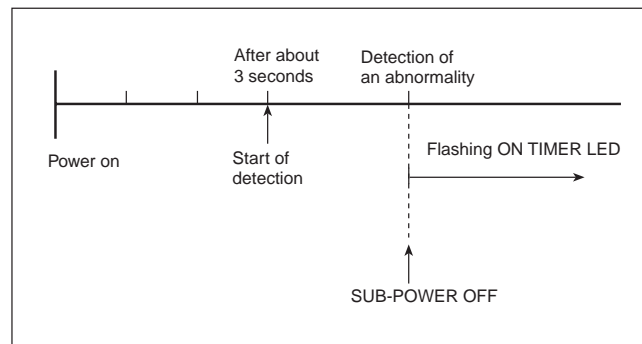

#### [ Indication by the LED ]

Item	LED flashing intervals
Over-current and CRT NECK protection	At 0.24-second intervals

# PARTS LIST

## CAUTION

- The parts identified by the  $\triangle$  symbol are important for the safety. Whenever replacing these parts, be sure to use specified ones to secure the safety.
- The parts not indicated in this Parts List and those which are filled with lines — in the Parts No. columns will not be supplied.
- P. W. Board Ass'y will not be supplied, but those which are filled with the Parts No. in the Parts No. columns will be supplied.

## ABBREVIATIONS OF RESISTORS, CAPACITORS AND TOLERANCES

RESISTORS		CAPACITORS	
C R	Carbon Resistor	C CAP.	Ceramic Capacitor
F R	Fusible Resistor	E CAP.	Electrolytic Capacitor
P R	Plate Resistor	M CAP.	Mylar Capacitor
V R	Variable Resistor	HV CAP.	High Voltage Capacitor
HV R	High Voltage Resistor	MF CAP.	Metalized Film Capacitor
MF R	Metal Film Resistor	MM CAP.	Metalized Mylar Capacitor
MG R	Metal Glazed Resistor	MP CAP.	Metalized Polystyrol Capacitor
MP R	Metal Plate Resistor	PP CAP.	Polypropylene Capacitor
OM R	Metal Oxide Film Resistor	PS CAP.	Polystyrol Capacitor
CMF R	Coating Metal Film Resistor	TF CAP.	Thin Film Capacitor
UNF R	Non-Flammable Resistor	MPP CAP.	Metalized Polypropylene Capacitor
CH V R	Chip Variable Resistor	TAN. CAP.	Tantalum Capacitor
CH MG R	Chip Metal Glazed Resistor	CH C CAP.	Chip Ceramic Capacitor
COMP. R	Composition Resistor	BP E CAP.	Bi-Polar Electrolytic Capacitor
LPTC R	Linear Positive Temperature Coefficient Resistor	CH AL E CAP.	Chip Aluminum Electrolytic Capacitor
NETW R	Network Resistor	CH AL BP CAP.	Chip Aluminum Bi-Polar Capacitor
		CH TAN. E CAP.	Chip Tantalum Electrolytic Capacitor
		CH AL BP E CAP.	Chip Tantalum Bi-Polar Electrolytic Capacitor

TOLERANCES									
F	G	J	K	M	N	R	H	Z	P
±1%	±2%	±5%	±10%	±20%	±30%	+30%	+50%	+80%	+100%
						-10%	-10%	-20%	-0%

# CONTENTS

- P.W. BOARD ..... 28
- EXPLODED VIEW PARTS LIST ..... 28
- EXPLODED VIEW ..... 29
- PRINTED WIRING BOARD PARTS LIST
  - MAIN PW BOARD ASS'Y ..... 30
- PACKING ..... 34
- PACKING PARTS LIST ..... 34
- REMOTE CONTROL UNIT PARTS LIST ..... 34

## P.W. BOARD

P.W.B. ASS'Y	Part No.
MAIN P.W.B.	SCG-1247A-H2

## EXPLODED VIEW PARTS LIST

△ Ref.No.	Part No.	Part Name	Description	Local
△ V01	A51LMV20X	PICTURE TUBE		
DY01	CE20336-00A	DEF YOKE		
△ L01	QQW0006-001	DEGAUSSING COIL		
△ T1522	QQH0069-001	H.V. TRANSF.		
1	GG10047-002A-H	FRONT CABINET ASSY		
2	CM43094-009-H	JVC MARK		
3	CM36375-001-H	CDS WINDOW		
4	CM36516-004-H	POWER KNOB		
5	CM35235-012-H	SPRING		
6	CM36518-001-H	LED LENS		
7	CM36517-004-H	CONTROL KNOB		
8	CE42153-00AJ1	WEDGE ASSY	(x4)	
9	A75034-B	PC MAGNET	or CE42378-00B	
10	CHGB0016-0B-FH	BRAIDED ASSY		
11	A48457-3-H	SPRING		
12	CEBSS09D-05KJ2	SPEAKER	(x2) SP01	
13	CM48144-002-H	PB STOPPER		
△ 14	CM12863-002-MH	REAR COVER		
△ 15	LC20377-010B-H	RATING LABEL		
16	QYSBSF3010Z	TAPPING SCREW		
△ 17	CM23167-A01-H	CORD CLAMP		
△ 18	QMP40D0-200J5	POWER CORD	or QMP40D0-200J3	
19	QYSBSFG4016Z	TAPPING SCREW	(x6)	
20	CM36617-B01-H	BACK BOARD		

# EXPLODED VIEW

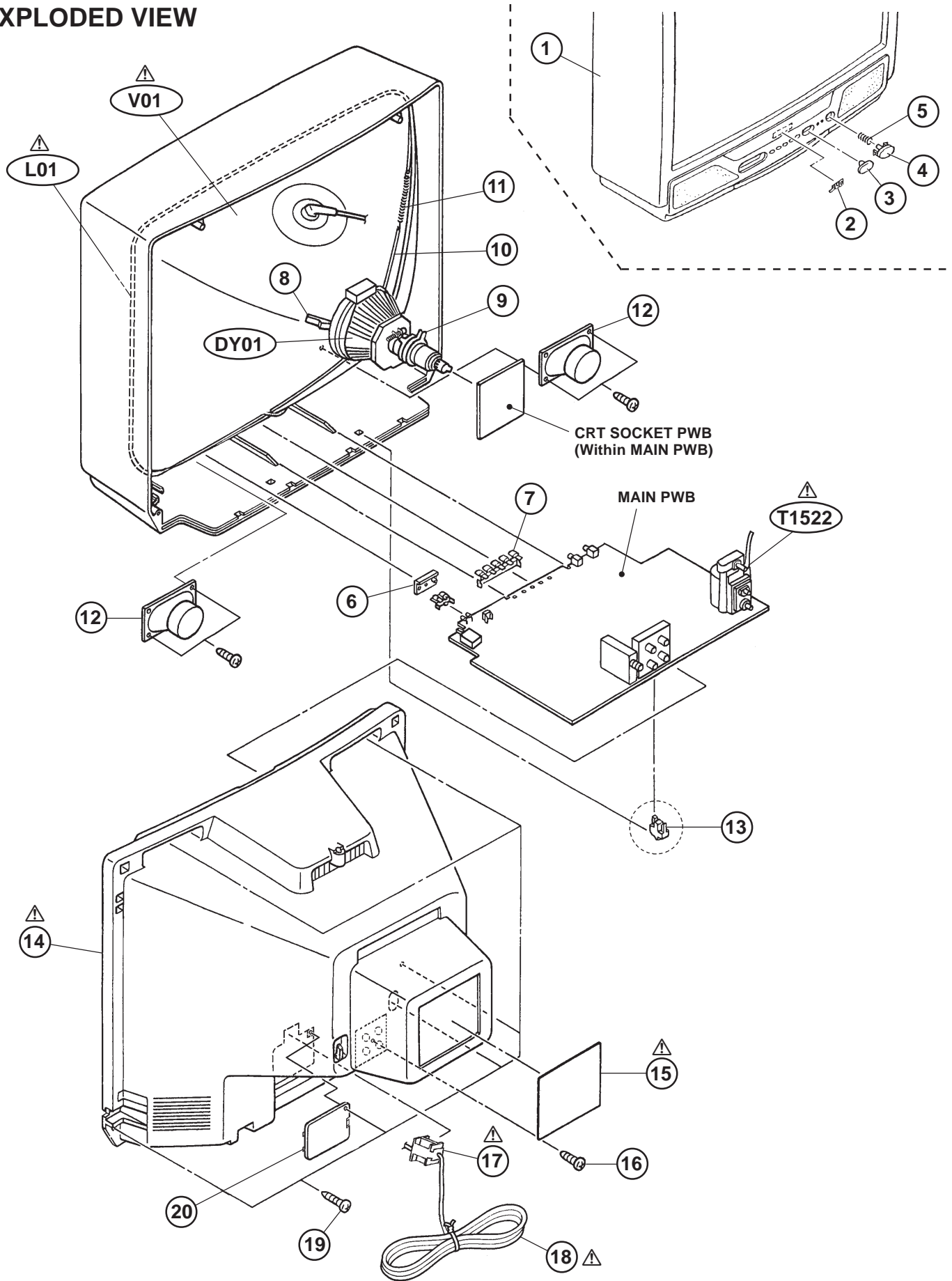

## PRINTED WIRING BOARD PARTS LIST

## MAIN P.W. BOARD ASS'Y (SCG-1247A-H2)

Symbol No.	Part No.	Part Name	Description	Local	Symbol No.	Part No.	Part Name	Description	Local
<b>RESISTOR</b>					<b>RESISTOR</b>				
R1002	NRSA02J-221X	CH MG R	220Ω 1/10W	J	R1442	NRSA02J-103X	CH MG R	10kΩ 1/10W	J
R1003	NRSA02J-221X	CH MG R	220Ω 1/10W	J	R1443	QRE121J-1R0Y	C R	1.0kΩ 1/2W	J
R1004	NRSA02J-563X	CH MG R	56kΩ 1/10W	J	R1453	NRSA02J-272X	CH MG R	2.7kΩ 1/10W	J
R1102	NRSA02J-750X	CH MG R	75Ω 1/10W	J	R1501	QRE121J-221Y	C R	220Ω 1/2W	J
R1103	NRSA02J-100X	CH MG R	10Ω 1/10W	J	R1502	NRSA02J-0R0X	CH MG R	0.0Ω 1/10W	J
R1109	NRSA02J-682X	CH MG R	6.8kΩ 1/10W	J	R1503	NRSA02J-682X	CH MG R	6.8kΩ 1/10W	J
R1110	NRSA02J-272X	CH MG R	2.7kΩ 1/10W	J	R1521	NRSA02J-681X	CH MG R	680Ω 1/10W	J
R1111	NRSA02J-181X	CH MG R	180Ω 1/10W	J	R1522	NRSA02J-103X	CH MG R	10kΩ 1/10W	J
R1112	NRSA02J-100X	CH MG R	10Ω 1/10W	J	R1524	QRL02EJ-820X	OM R	82Ω 2W	J
R1113	NRSA02J-101X	CH MG R	100Ω 1/10W	J	R1525	QRL02EJ-820X	OM R	82Ω 2W	J
R1114	NRSA02J-472X	CH MG R	4.7kΩ 1/10W	J	R1526	QRE121J-270Y	C R	27Ω 1/2W	J
R1115	NRSA02J-222X	CH MG R	2.2kΩ 1/10W	J	R1530	QRE121J-223Y	C R	22kΩ 1/2W	J
R1117	NRSA02J-0R0X	CH MG R	0.0Ω 1/10W	J	R1531	NRSA02J-472X	CH MG R	4.7kΩ 1/10W	J
R1118	NRSA02J-222X	CH MG R	2.2kΩ 1/10W	J	R1533	NRSA02J-332X	CH MG R	3.3kΩ 1/10W	J
R1120	NRSA02J-391X	CH MG R	390Ω 1/10W	J	R1534	NRSA02J-332X	CH MG R	3.3kΩ 1/10W	J
R1121	NRSA02J-221X	CH MG R	220Ω 1/10W	J	△ R1551	QRZ9011-1R0	F R	1.0Ω 1/2W	J
R1159	NRSA02J-184X	CH MG R	180kΩ 1/10W	J	R1552	QRJ146J-2R2X	C R	2.2Ω 1/4W	J
R1301	NRSA02J-221X	CH MG R	220Ω 1/10W	J	R1554	QRE121J-681Y	C R	680Ω 1/2W	J
R1302	NRSA02J-472X	CH MG R	4.7kΩ 1/10W	J	R1571	QRE121J-222Y	C R	2.2kΩ 1/2W	J
R1303	NRSA02J-101X	CH MG R	100Ω 1/10W	J	R1573	QRT02EJ-1R5X	OM R	1.5Ω 2W	J
R1304	NRSA02J-101X	CH MG R	100Ω 1/10W	J	R1574	QRT02EJ-1R5X	OM R	1.5Ω 2W	J
R1305	NRSA02J-101X	CH MG R	100Ω 1/10W	J	R1576	QRE121J-223Y	C R	22kΩ 1/2W	J
R1306	NRSA02J-221X	CH MG R	220Ω 1/10W	J	R1577	NRSA02J-392X	CH MG R	3.9kΩ 1/10W	J
R1307	NRSA02J-122X	CH MG R	1.2kΩ 1/10W	J	R1578	NRSA02J-103X	CH MG R	10kΩ 1/10W	J
R1308	NRSA02J-182X	CH MG R	1.8kΩ 1/10W	J	R1581	QRE121J-182Y	C R	1.8kΩ 1/2W	J
R1312	NRSA02J-0R0X	CH MG R	0.0Ω 1/10W	J	R1582	NRSA02J-223X	CH MG R	22kΩ 1/10W	J
R1313	NRSA02J-102X	CH MG R	1kΩ 1/10W	J	R1583	NRSA02J-393X	CH MG R	39kΩ 1/10W	J
R1314	NRSA02J-102X	CH MG R	1kΩ 1/10W	J	R1651	NRSA02J-103X	CH MG R	10kΩ 1/10W	J
R1321	NRSA02J-152X	CH MG R	1.5kΩ 1/10W	J	R1652	NRSA02J-821X	CH MG R	820Ω 1/10W	J
R1322	NRSA02J-272X	CH MG R	2.7kΩ 1/10W	J	R1653	QRE121J-1R0Y	C R	1.0kΩ 1/2W	J
R1323	NRSA02J-103X	CH MG R	10kΩ 1/10W	J	R1654	QRX029J-4R7	OM R	4.7Ω 2W	J
R1324	NRSA02J-102X	CH MG R	1kΩ 1/10W	J	R1656	NRSA02J-123X	CH MG R	12kΩ 1/10W	J
R1326	NRSA02J-101X	CH MG R	100Ω 1/10W	J	R1657	NRSA02J-391X	CH MG R	390Ω 1/10W	J
R1327	NRSA02J-475X	CH MG R	4.7MΩ 1/10W	J	R1658	NRSA02J-102X	CH MG R	1kΩ 1/10W	J
R1341	NRSA02J-332X	CH MG R	3.3kΩ 1/10W	J	R1659	NRSA02J-102X	CH MG R	1kΩ 1/10W	J
R1347	NRSA02J-392X	CH MG R	3.9kΩ 1/10W	J	R1660	NRSA02J-103X	CH MG R	10kΩ 1/10W	J
R1349	NRSA02J-123X	CH MG R	12kΩ 1/10W	J	R1661	QRE121J-271Y	C R	270Ω 1/2W	J
R1351	NRSA02J-151X	CH MG R	150Ω 1/10W	J	R1662	QRE121J-271Y	C R	270Ω 1/2W	J
R1352	NRSA02J-151X	CH MG R	150Ω 1/10W	J	R1664	NRSA02J-221X	CH MG R	220Ω 1/10W	J
R1353	NRSA02J-151X	CH MG R	150Ω 1/10W	J	R1665	NRSA02J-103X	CH MG R	10kΩ 1/10W	J
R1354	NRSA02J-331X	CH MG R	330Ω 1/10W	J	R1701	NRSA02J-562X	CH MG R	5.6kΩ 1/10W	J
R1355	NRSA02J-331X	CH MG R	330Ω 1/10W	J	R1702	NRSA02J-682X	CH MG R	6.8kΩ 1/10W	J
R1356	NRSA02J-331X	CH MG R	330Ω 1/10W	J	R1703	NRSA02J-392X	CH MG R	3.9kΩ 1/10W	J
R1357	NRSA02J-101X	CH MG R	100Ω 1/10W	J	R1704	NRSA02J-221X	CH MG R	220Ω 1/10W	J
R1358	NRSA02J-101X	CH MG R	100Ω 1/10W	J	R1705	NRSA02J-221X	CH MG R	220Ω 1/10W	J
R1359	NRSA02J-101X	CH MG R	100Ω 1/10W	J	R1706	NRSA02J-561X	CH MG R	560Ω 1/10W	J
R1360	QRZ0107-152Z	C R	1.5kΩ 1/2W	K	R1707	NRSA02J-561X	CH MG R	560Ω 1/10W	J
R1361	QRZ0107-152Z	C R	1.5kΩ 1/2W	K	R1708	NRSA02J-102X	CH MG R	1kΩ 1/10W	J
R1362	QRZ0107-152Z	C R	1.5kΩ 1/2W	K	R1709	NRSA02J-472X	CH MG R	4.7kΩ 1/10W	J
R1363	QRL029J-123	OM R	12kΩ 2W	J	R1710	NRSA02J-472X	CH MG R	4.7kΩ 1/10W	J
R1364	QRL029J-123	OM R	12kΩ 2W	J	R1711	NRSA02J-472X	CH MG R	4.7kΩ 1/10W	J
R1365	QRL029J-123	OM R	12kΩ 2W	J	R1712	NRSA02J-472X	CH MG R	4.7kΩ 1/10W	J
R1366	NRSA02J-182X	CH MG R	1.8kΩ 1/10W	J	R1713	NRSA02J-472X	CH MG R	4.7kΩ 1/10W	J
R1367	NRSA02J-182X	CH MG R	1.8kΩ 1/10W	J	R1714	NRSA02J-472X	CH MG R	4.7kΩ 1/10W	J
R1368	NRSA02J-182X	CH MG R	1.8kΩ 1/10W	J	R1715	NRSA02J-221X	CH MG R	220Ω 1/10W	J
R1369	QRE121J-394Y	C R	390kΩ 1/2W	J	R1716	NRSA02J-221X	CH MG R	220Ω 1/10W	J
R1372	NRSA02J-0R0X	CH MG R	0.0Ω 1/10W	J	R1718	NRSA02J-561X	CH MG R	560Ω 1/10W	J
R1374	NRSA02J-392X	CH MG R	3.9kΩ 1/10W	J	R1719	NRSA02J-102X	CH MG R	1kΩ 1/10W	J
R1401	NRSA02J-103X	CH MG R	10kΩ 1/10W	J	R1720	NRSA02J-472X	CH MG R	4.7kΩ 1/10W	J
R1421	NRSA02J-122X	CH MG R	1.2kΩ 1/10W	J	R1721	NRSA02J-103X	CH MG R	10kΩ 1/10W	J
R1422	NRSA02J-122X	CH MG R	1.2kΩ 1/10W	J	△ R1723	QRZ9023-270	F R	27Ω 2W	J
R1423	NRSA02J-331X	CH MG R	330Ω 1/10W	J	R1725	NRSA02J-102X	CH MG R	1kΩ 1/10W	J
R1424	NRSA02J-101X	CH MG R	100Ω 1/10W	J	R1726	NRSA02J-472X	CH MG R	4.7kΩ 1/10W	J
R1425	NRSA02J-471X	CH MG R	470Ω 1/10W	J	R1727	NRSA02J-153X	CH MG R	15kΩ 1/10W	J
R1426	NRSA02J-0R0X	CH MG R	0.0Ω 1/10W	J	R1728	NRSA02J-102X	CH MG R	1kΩ 1/10W	J
R1429	NRSA02J-103X	CH MG R	10kΩ 1/10W	J	R1729	NRSA02J-102X	CH MG R	1kΩ 1/10W	J
R1430	NRSA02J-823X	CH MG R	82kΩ 1/10W	J	R1730	NRSA02J-103X	CH MG R	10kΩ 1/10W	J
R1431	NRSA02J-103X	CH MG R	10kΩ 1/10W	J	R1731	NRSA02J-472X	CH MG R	4.7kΩ 1/10W	J
R1432	QRE121J-2R7Y	C R	2.7Ω 1/2W	J	R1736	NRSA02J-823X	CH MG R	82kΩ 1/10W	J
R1433	QRE121J-2R7Y	C R	2.7Ω 1/2W	J	R1737	NRSA02J-104X	CH MG R	100kΩ 1/10W	J
R1436	NRSA02J-823X	CH MG R	82kΩ 1/10W	J	R1738	NRSA02J-103X	CH MG R	10kΩ 1/10W	J
R1440	QRE121J-471Y	C R	470Ω 1/2W	J	R1739	NRSA02J-103X	CH MG R	10kΩ 1/10W	J
R1441	NRSA02J-822X	CH MG R	8.2kΩ 1/10W	J	R1740	NRSA02J-392X	CH MG R	3.9kΩ 1/10W	J

Symbol No.	Part No.	Part Name	Description	Local
<b>RESISTOR</b>				
R1741	NRSA02J-561X	CH MG R	560Ω 1/10W J	
R1742	NRSA02J-563X	CH MG R	56kΩ 1/10W J	
R1746	NRSA02J-103X	CH MG R	10kΩ 1/10W J	
R1747	NRSA02J-0R0X	CH MG R	0.0Ω 1/10W J	
R1748	NRSA02J-103X	CH MG R	10kΩ 1/10W J	
R1749	NRSA02J-472X	CH MG R	4.7kΩ 1/10W J	
R1771	NRSA02J-821X	CH MG R	820Ω 1/10W J	
R1772	NRSA02J-821X	CH MG R	820Ω 1/10W J	
R1791	NRSA02J-221X	CH MG R	220Ω 1/10W J	
R1792	NRSA02J-221X	CH MG R	220Ω 1/10W J	
R1793	NRSA02J-221X	CH MG R	220Ω 1/10W J	
R1794	NRSA02J-221X	CH MG R	220Ω 1/10W J	
R1795	NRSA02J-221X	CH MG R	220Ω 1/10W J	
R1796	NRSA02J-103X	CH MG R	10kΩ 1/10W J	
R1797	NRSA02J-153X	CH MG R	15kΩ 1/10W J	
R1802	NRSA02J-750X	CH MG R	75Ω 1/10W J	
R1806	QRE121J-271Y	C R	270Ω 1/2W J	
R1807	NRSA02J-680X	CH MG R	68Ω 1/10W J	
R1810	QRG016J-560	OM R	56Ω 1W J	
R1811	NRSA02J-221X	CH MG R	220Ω 1/10W J	
R1815	QRE121J-181Y	C R	180Ω 1/2W J	
R1816	NRSA02J-681X	CH MG R	680Ω 1/10W J	
R1817	NRSA02J-472X	CH MG R	4.7kΩ 1/10W J	
R1901	QRF104K-3R9	UNF R	3.9Ω 10W K	
R1903	QRL02EJ-683X	OM R	68kΩ 2W J	
R1921	QRE121J-681Y	C R	680Ω 1/2W J	
R1922	QRT029J-1R2	MF R	1.2Ω 2W J	
R1923	QRM059J-R22	MP R	0.22Ω 5W J	
R1926	NRSA02J-222X	CH MG R	2.2kΩ 1/10W J	
R1928	QRL03EJ-563X	OM R	56kΩ 3W J	
R1929	QRE121J-822Y	C R	8.2kΩ 1/2W J	
R1932	QRE121J-564Y	C R	560kΩ 1/2W J	
R1933	QRE121J-180Y	C R	18Ω 1/2W J	
R1934	NRSA02J-333X	CH MG R	33kΩ 1/10W J	
R1936	QRG016J-561	OM R	560Ω 1W J	
R1941	QRE121J-821Y	C R	820Ω 1/2W J	
R1942	NRSA02J-122X	CH MG R	1.2kΩ 1/10W J	
R1943	NRSA02J-473X	CH MG R	47kΩ 1/10W J	
R1944	NRSA02J-103X	CH MG R	10kΩ 1/10W J	
R1974	NRSA02J-222X	CH MG R	2.2kΩ 1/10W J	
R1976	NRSA02J-102X	CH MG R	1kΩ 1/10W J	
R1977	QRE121J-122Y	C R	1.2kΩ 1/2W J	
R1978	NRSA02J-473X	CH MG R	47kΩ 1/10W J	
R1979	QRT02EJ-2R7X	OM R	2.7Ω 2W J	
R1980	QRL02EJ-103X	OM R	10kΩ 2W J	
Δ R1991	QRZ0057-825	C R	8.2MΩ 1W J	

**CAPACITOR**

C1001	QETN1HM-106Z	E CAP.	10μF 50V M
C1002	NCB21HK-103X	CH C CAP.	0.01μF 50V K
C1004	QETN1CM-227Z	E CAP.	220μF 16V M
C1005	QFV71HJ-104Z	TF CAP.	0.1μF 50V J
C1008	QETN1HM-475Z	E CAP.	4.7μF 50V M
C1103	QETN1EM-476Z	E CAP.	47μF 25V M
C1104	NCB21HK-472X	CH C CAP.	4700pF 50V K
C1105	NCB21HK-472X	CH C CAP.	4700pF 50V K
C1106	NCB21HK-472X	CH C CAP.	4700pF 50V K
C1107	NCB21HK-472X	CH C CAP.	4700pF 50V K
C1109	NCB21HK-472X	CH C CAP.	4700pF 50V K
C1110	NRSA02J-0R0X	CH MG R	0.0Ω 1/10W J
C1112	QETN1EM-476Z	E CAP.	47μF 25V M
C1113	NCB21HK-472X	CH C CAP.	4700pF 50V K
C1115	NCB21HK-103X	CH C CAP.	0.01μF 50V K
C1116	NCB21HK-103X	CH C CAP.	0.01μF 50V K
C1117	QFV71HJ-224Z	TF CAP.	0.22μF 50V J
C1119	QETN1HM-474Z	E CAP.	0.47μF 50V M
C1120	NDC21HJ-121X	CH C CAP.	120pF 50V J
C1121	NCB21HK-103X	CH C CAP.	0.01μF 50V K
C1122	NCB21HK-103X	CH C CAP.	0.01μF 50V K
C1162	NDC21HJ-681X	CH C CAP.	680pF 50V J
C1301	NCB21HK-123X	CH C CAP.	0.012μF 50V K
C1302	QETN1HM-475Z	E CAP.	4.7μF 50V M
C1303	NDC21HJ-100X	CH C CAP.	10pF 50V J
C1304	QFV71HJ-474Z	TF CAP.	0.47μF 50V J

Symbol No.	Part No.	Part Name	Description	Local
<b>CAPACITOR</b>				
C1305	QETN1HM-474Z	E CAP.	0.47μF 50V M	
C1306	NCB21HK-103X	CH C CAP.	0.01μF 50V K	
C1307	QETN1CM-477Z	E CAP.	470μF 16V M	
C1308	QETN1CM-107Z	E CAP.	100μF 16V M	
C1309	NCB21HK-103X	CH C CAP.	0.01μF 50V K	
C1310	NDC21HJ-221X	CH C CAP.	220pF 50V J	
C1311	NCB21HK-103X	CH C CAP.	0.01μF 50V K	
C1312	QENC1HM-474Z	BP E CAP.	0.47μF 50V M	
C1313	QETN1HM-335Z	E CAP.	3.3μF 50V M	
C1314	NCB21HK-103X	CH C CAP.	0.01μF 50V K	
C1315	QETN1CM-107Z	E CAP.	100μF 16V M	
C1316	QETN1HM-106Z	E CAP.	10μF 50V M	
C1317	NCB21HK-473X	CH C CAP.	0.047μF 50V K	
C1321	NDC21HJ-120X	CH C CAP.	12pF 50V J	
C1322	NCB21HK-273X	CH C CAP.	0.027μF 50V K	
C1323	QETN1HM-474Z	E CAP.	0.47μF 50V M	
C1324	QETN1HM-106Z	E CAP.	10μF 50V M	
C1325	QENC1HM-106Z	BP E CAP.	10μF 50V M	
C1326	NCS21HJ-221X	CH C CAP.	220pF 50V J	
C1341	QETN1HM-106Z	E CAP.	10μF 50V M	
C1352	QFZ0097-103	MM CAP.	0.01μF 1250V K	
C1354	NDC21HJ-271X	CH C CAP.	270pF 50V J	
C1355	NDC21HJ-221X	CH C CAP.	220pF 50V J	
C1356	NDC21HJ-331X	CH C CAP.	330pF 50V J	
C1357	QETN1AM-477Z	E CAP.	470μF 10V M	
C1365	QENC1HM-105Z	BP E CAP.	1μF 50V M	
C1366	QENC1HM-105Z	BP E CAP.	1μF 50V M	
C1367	QENC1HM-105Z	BP E CAP.	1μF 50V M	
C1401	QFV71HJ-474Z	TF CAP.	0.47μF 50V J	
C1402	QFV71HJ-104Z	TF CAP.	0.1μF 50V J	
C1422	QETN1HM-105Z	E CAP.	1μF 50V M	
C1423	QCS32HJ-100Z	C CAP.	10pF 500V J	
C1424	QFLC2AJ-103Z	M CAP.	0.01μF 100V J	
C1426	QFLC1HJ-102Z	M CAP.	1000pF 50V J	
C1427	QETN1VM-107Z	E CAP.	100μF 35V M	
C1428	QHR1VM-107Z	E CAP.	100μF 35V M	
C1429	QETN1HM-106Z	E CAP.	10μF 50V M	
C1430	QFN32AJ-472Z	M CAP.	4700pF 100V J	
C1433	QHR1HM-475Z	E CAP.	4.7μF 50V M	
C1435	QETM1EM-228	E CAP.	2200μF 25V M	
C1436	QFV71HJ-334Z	TF CAP.	0.33μF 50V J	
C1501	QETN1AM-227Z	E CAP.	220μF 10V M	
C1502	NCB21HK-103X	CH C CAP.	0.01μF 50V K	
C1503	QETN1HM-106Z	E CAP.	10μF 50V M	
C1523	QTMN1VM-476Z	E CAP.	47μF 35V M	
C1525	QFZ0200-103	MPP CAP.	0.01μF 1.5kVH ±3%	
C1526	QTMN1EM-337Z	E CAP.	330μF 25V M	
C1527	QFZ0199-334	MPP CAP.	0.33μF 250V J	
C1528	QETN2EM-475Z	E CAP.	4.7μF 250V M	
C1531	QEZO203-107	E CAP.	100μF 160V M	
C1552	QETM1VM-108	E CAP.	1000μF 35V M	
C1554	QETN2EM-475Z	E CAP.	4.7μF 250V M	
C1555	QFLC2AJ-104Z	M CAP.	0.1μF 100V J	
C1571	QETN1AM-107Z	E CAP.	100μF 10V M	
C1572	QETN1EM-476Z	E CAP.	47μF 25V M	
C1581	QFV71HJ-104Z	TF CAP.	0.1μF 50V J	
C1582	QFZ0199-104	MPP CAP.	0.1μF 250V J	
C1651	QTNC1HM-105Z	BP E CAP.	1μF 50V M	
C1652	QHR1HM-106Z	E CAP.	10μF 50V M	
C1653	QETN1HM-474Z	E CAP.	0.47μF 50V M	
C1654	NCB21HK-104X	CH C CAP.	0.1μF 50V K	
C1655	QHQ1VM-228	E CAP.	2200μF 35V M	
C1656	QHR1EM-477Z	E CAP.	470μF 25V M	
C1658	QETN1HM-226Z	E CAP.	22μF 50V M	
C1659	QETN1CM-107Z	E CAP.	100μF 16V M	
C1663	QHR1HM-106Z	E CAP.	10μF 50V M	
C1664	NCB21HK-104X	CH C CAP.	0.1μF 50V K	
C1665	QHR1HM-105Z	E CAP.	1μF 50V M	
C1701	QETN1HM-106Z	E CAP.	10μF 50V M	
C1705	QETN1CM-477Z	E CAP.	470μF 16V M	
C1706	NCB21EK-104X	CH C CAP.	0.1μF 25V K	
C1707	NCB21HK-103X	CH C CAP.	0.01μF 50V K	
C1708	QETN1EM-476Z	E CAP.	47μF 25V M	
C1709	NCB21HK-103X	CH C CAP.	0.01μF 50V K	
C1710	QETN1CM-107Z	E CAP.	100μF 16V M	
C1711	NCB21HK-103X	CH C CAP.	0.01μF 50V K	

Symbol No.	Part No.	Part Name	Description	Local
<b>CAPACITOR</b>				
C1712	NCB21HK-103X	CH C CAP.	0.01μF 50V	K
C1713	NCB21HK-103X	CH C CAP.	0.01μF 50V	K
C1714	NDC21HJ-330X	CH C CAP.	33pF 50V	J
C1715	NDC21HJ-330X	CH C CAP.	33pF 50V	J
C1716	NDC21HJ-181X	CH C CAP.	180pF 50V	J
C1717	NDC21HJ-181X	CH C CAP.	180pF 50V	J
C1718	NCB21HK-103X	CH C CAP.	0.01μF 50V	K
C1719	QETN1HM-105Z	E CAP.	1μF 50V	M
C1720	NCB21HK-103X	CH C CAP.	0.01μF 50V	K
C1721	NCB21HK-333X	CH C CAP.	0.033μF 50V	K
C1722	NDC21HJ-101X	CH C CAP.	100pF 50V	J
C1724	NDC21HJ-560X	CH C CAP.	56pF 50V	J
C1728	NDC21HJ-181X	CH C CAP.	180pF 50V	J
C1729	NDC21HJ-181X	CH C CAP.	180pF 50V	J
C1730	NCB21HK-103X	CH C CAP.	0.01μF 50V	K
C1738	QETN1HM-226Z	E CAP.	22μF 50V	M
C1744	NCB21HK-103X	CH C CAP.	0.01μF 50V	K
C1805	QETN1CM-227Z	E CAP.	220μF 16V	M
C1806	QETN1CM-477Z	E CAP.	470μF 16V	M
C1811	QETN1HM-106Z	E CAP.	10μF 50V	M
C1841	NCB21HK-152X	CH C CAP.	1500pF 50V	J
△ C1901	QFZ9040-104	MF CAP.	0.1μF AC275V	M
C1904	QCZ9078-222	C CAP.	2200pF AC250V	M
C1905	QCZ9078-222	C CAP.	2200pF AC250V	M
C1907	QCZ9078-222	C CAP.	2200pF AC250V	M
C1909	QEZ0199-127	E CAP.	120μF 400V	M
△ C1910	QFZ9040-473	MF CAP.	0.047μF AC275V	M
C1922	QFLC1HJ-471Z	M CAP.	470pF 50V	J
C1924	QETN1VM-107Z	E CAP.	100μF 35V	M
C1926	QFLC1HJ-332Z	M CAP.	3300pF 50V	J
C1928	NCB21HK-473X	CH C CAP.	0.047μF 50V	K
C1929	QFP32GJ-223Z	PP CAP.	0.022μF 400V	J
C1930	QCZ0325-561	C CAP.	560pF 2kV	K
C1931	QCZ0325-151	C CAP.	150pF 2kV	K
C1932	QCZ0325-151	C CAP.	150pF 2kV	K
C1941	QCZ0122-561	C CAP.	560pF 2kV	K
C1942	QEZ0420-107	E CAP.	100μF 160V	M
C1945	QEHR1CM-108Z	E CAP.	1000μF 16V	M
C1946	QEHR1CM-477Z	E CAP.	470μF 16V	M
C1948	QEHR1VM-108Z	E CAP.	1000μF 35V	M
C1949	NDC21HJ-471X	CH C CAP.	470pF 50V	J
C1950	NCB21HK-104X	CH C CAP.	0.1μF 50V	K
C1971	QETN1HM-475Z	E CAP.	4.7μF 50V	M
C1976	QETN1HM-105Z	E CAP.	1μF 50V	M
C1977	QETN1CM-477Z	E CAP.	470μF 16V	M
C1978	QETN1CM-227Z	E CAP.	220μF 16V	M
C1979	QETN1CM-107Z	E CAP.	100μF 16V	M
△ C1991	QCZ9079-471	C CAP.	470pF AC250V	K
△ C1992	QCZ9079-471	C CAP.	470pF AC250V	K
△ C1993	QCZ9079-102	C CAP.	1000pF AC250V	K

**TRANSFORMER**

△ T1522	QQH0069-001	H.V. TRANSF.
△ T1921	QSQ0050-001	SW TRANSF.

**COIL**

L1001	QQL244K-8R2Z	COIL	8.2μH	K
L1101	QQL2014-2R2	COIL	2.2μH	
L1103	QQL244K-8R2Z	COIL	8.2μH	K
L1351	QQL244K-470Z	COIL	47μH	K
L1352	QQL244K-470Z	COIL	47μH	K
L1353	QQL244K-470Z	COIL	47μH	K
L1523	QQL342J-2R2Z	INDUCTOR		
L1551	QQL2018-380	HEATER CHOKE		
L1701	QQL244J-5R6Z	COIL		
L1941	QQL26AK-820Z	CHOKE COIL		
L1942	QQL26AK-820Z	CHOKE COIL		
L1943	QQL26AK-820Z	CHOKE COIL		

Symbol No.	Part No.	Part Name	Description	Local
<b>DIODE</b>				
D1001	MA3330/L/-X	CHIP ZENER DIODE		
D1102	1S585-T2	SI DIODE		
D1301	MA3091/M/-X	CHIP ZENER DIODE		
D1302	MA3091/M/-X	CHIP ZENER DIODE		
D1305	RB100A-T2	SI DIODE		
D1341	MA111-X	CHIP DIODE		
D1342	MA111-X	CHIP DIODE		
D1351	MA3056/L/-X	CHIP ZENER DIODE		
D1352	MA3056/L/-X	CHIP ZENER DIODE		
D1353	MA3056/L/-X	CHIP ZENER DIODE		
D1354	MA111-X	CHIP DIODE		
D1355	MA111-X	CHIP DIODE		
D1356	MA111-X	CHIP DIODE		
D1421	MA3360/M/-X	CHIP ZENER DIODE		
D1422	MA3360/M/-X	CHIP ZENER DIODE		
D1423	1SR124-400A-T2	SI DIODE		
D1424	MA111-X	CHIP DIODE		
D1425	MA111-X	CHIP DIODE		
D1427	MA3270/H/-X	CHIP ZENER DIODE		
D1551	RGPI0J-TS-T3	SI DIODE		
D1552	RH1S-T3	SI DIODE		
D1553	MA3091/M/-X	CHIP ZENER DIODE		
D1554	MA111-X	CHIP DIODE		
D1555	1SR124-400A-T2	SI DIODE		
D1571	MA3075/M/-X	CHIP ZENER DIODE		
D1581	MA3200/M/-X	CHIP ZENER DIODE		
D1582	RGPI0J-TS-T3	SI DIODE		
D1651	MA111-X	CHIP DIODE		
D1652	MA111-X	CHIP DIODE		
D1653	MTZJ18A-T2	ZENER DIODE		
D1701	MA111-X	CHIP DIODE		
D1704	L-132XID-T16	LED (RED)		
D1705	L-132XND-T16	LED (ORG)		
D1706	MA111-X	CHIP DIODE		
D1707	MA111-X	CHIP DIODE		
D1731	MA111-X	CHIP DIODE		
D1791	MA3056/M/-X	CHIP ZENER DIODE		
D1792	MA3056/M/-X	CHIP ZENER DIODE		
D1793	MA3056/M/-X	CHIP ZENER DIODE		
D1794	MA3056/M/-X	CHIP ZENER DIODE		
D1795	MA3056/M/-X	CHIP ZENER DIODE		
D1901	G2SBA60	BRIDGE DIODE		
D1921	RGPI0J-TS-T3	SI DIODE		
D1922	MA111-X	CHIP DIODE		
D1923	MA111-X	CHIP DIODE		
D1924	MA111-X	CHIP DIODE		
D1926	MA3056/M/-X	CHIP ZENER DIODE		
D1927	MA3068/M/-X	CHIP ZENER DIODE		
D1929	RD12E/B2/-T5	ZENER DIODE		
D1930	EG1A-T3	SI DIODE		
D1932	MA111-X	CHIP DIODE		
D1933	RD27E/B2/-T5	ZENER DIODE		
D1941	RU3AM-LFC4	SI DIODE		
D1942	RU3YX-LFC4	SI DIODE		
D1943	RGPI0J-TS-T3	SI DIODE		
D1945	MA3075/H/-X	CHIP ZENER DIODE		
D1982	MA111-X	CHIP DIODE		
D1983	MA111-X	CHIP DIODE		

**TRANSISTOR**

Q1102	2SC5083/L-P/-T	SI TRANSISTOR		
Q1103	DTC124EKA-X	DIGI TRANSISTOR		
Q1301	2SA1037AK/QR/-X	SI TRANSISTOR		
Q1302	2SC2412K/QR/-X	CHIP TRANSISTOR		
Q1351	2SC3271F	SI TRANSISTOR		
Q1352	2SC3271F	SI TRANSISTOR		
Q1353	2SC3271F	SI TRANSISTOR		
Q1401	DTC124ESA-T	DIGI TRANSISTOR		
Q1402	2SC2412K/QR/-X	CHIP TRANSISTOR		
Q1521	2SK3065-W	SI TRANSISTOR		
Q1522	BU808DFI-154Y	POWER TRANSISTOR		H. OUT
Q1523	2SC2412K/QR/-X	CHIP TRANSISTOR		
Q1524	2SC2412K/QR/-X	CHIP TRANSISTOR		
Q1571	2SA1208/ST/Z1-T	SI TRANSISTOR		



Symbol No.	Part No.	Part Name	Description	Local
<b>TRANSISTOR</b>				
Q1572	2SC2412K/QR/-X	CHIP TRANSISTOR		
Q1651	2SA1037AK/QR/-X	SI TRANSISTOR		
Q1652	DTC323TK-X	DIGI TRANSISTOR		
Q1654	2SC2412K/QR/-X	CHIP TRANSISTOR		
Q1655	2SC2412K/QR/-X	CHIP TRANSISTOR		
Q1702	2SC2412K/QR/-X	CHIP TRANSISTOR		
Q1703	2SC2412K/QR/-X	CHIP TRANSISTOR		
Q1708	DTC124EKA-X	DIGI TRANSISTOR		
Q1709	2SA1037AK/QR/-X	SI TRANSISTOR		
Q1803	2SC1815/YG/-T	SI TRANSISTOR		
Q1804	2SC2412K/QR/-X	CHIP TRANSISTOR		
Q1941	2SC2412K/QR/-X	CHIP TRANSISTOR		
Q1943	DTC114EKA-X	CHIP TRANSISTOR		
Q1974	2SA966/OY/-T	SI TRANSISTOR		
Q1975	DTC124EKA-X	DIGI TRANSISTOR		
<b>IC</b>				
IC1301	NN5198K	IC		
IC1421	AN5539-LF	IC		
IC1651	LA4287	IC		
IC1652	SI-5001X-X	IC		
IC1701	MN1873287JA	IC (MICROCOMPUTER)		
IC1702	AT24C08-21FTR	IC (MEMORY)	(Service)	
IC1703	L78LR05E-MA	IC (5V REG/RESET)		
IC1704	PIC-28143SY	IR DETECT UNIT		
IC1921	STR-G6653	IC (SW REG)		
IC1941	SE115N-LF12	IC		
IC1971	BA51W125T-V5	IC (5V/9V REG)		
<b>OTHERS</b>				
	CM35921-005-H	CDS HOLDER		
	LC30114-001C-H	LED HOLDER		
△ CP1981	ICP-N75-Y	IC PROTECTOR		
△ CP1982	ICP-N75-Y	IC PROTECTOR		
△ F1901	QMF51E2-3R15J4	FUSE	3.15A	
FC1901	CEMG002-001Z	FUSE CLIP (x2)		
J1002	CEMN075-001	PIN JACK		
J1003	QNN0281-003	PIN JACK		
J1004	QNN0281-002	PIN JACK		
J1005	QNS0165-001	3.5 JACK		
K1001	QQR0621-002Z	BEADS CORE		
K1351	QQR0621-002Z	BEADS CORE		
K1421	QQR0582-001Z	BEADS CORE		
K1921	QQR1113-001Z	FERRITE BEADS		
K1922	QQR1113-001Z	FERRITE BEADS		
K1923	QQR1114-001Z	FERRITE BEADS		
K1924	QQR1113-001Z	FERRITE BEADS		
K1941	QQR1113-001Z	FERRITE BEADS		
K1942	QQR1113-001Z	FERRITE BEADS		
K1943	QQR1113-001Z	FERRITE BEADS		
△ LF1901	QQR0527-002	LINE FILTER		
PC1701	P1241-04	CDS		
△ PC1921	PC123F2	PHOTO COUPLER		
S1701	QSW0619-003Z	PUSH SWITCH	VOL+	
S1702	QSW0619-003Z	PUSH SWITCH	VOL-	
S1703	QSW0619-003Z	PUSH SWITCH	CH+	
S1704	QSW0619-003Z	PUSH SWITCH	CH-	
S1705	QSW0619-003Z	PUSH SWITCH	MENU	
△ S1901	QSW0750-001	PUSH SWITCH	POWER	
SF1102	QAX0594-001	SAW FILTER		
SF1122	QAX0325-001	SAW FILTER		
△ SK1351	CE42446-001	CRT SOCKET		
TH1901	QAD0119-9R0	P THERMISTOR		
TU1001	QAU0185-001	TUNER		
△ VA1901	ERZV10V621CS	VARIATOR		
X1301	QAX0500-001Z	CRYSTAL		
X1302	CE42690-001Z	CRYSTAL		
X1701	FCR12.0M2S	C RESONATOR		

Symbol No.	Part No.	Part Name	Description	Local
------------	----------	-----------	-------------	-------

## PACKING

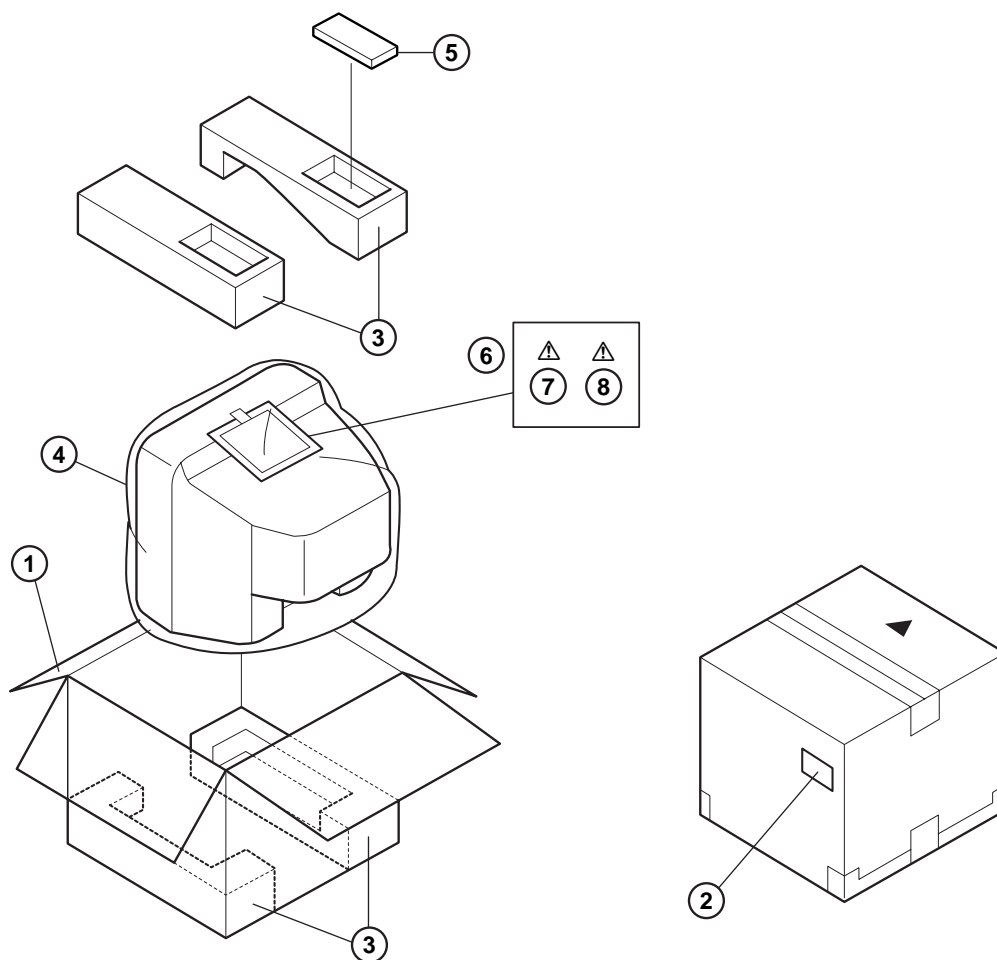

## PACKING PARTS LIST

△ Ref.No.	Part No.	Part Name	Description	Local
1	GG10056-017A-H	PACKING CASE		
2	CM47385-00B-H	POS/SERIAL LABEL		
3	CP11667-00B-H	CUSHION ASSY	4 pcs. in 1 set	
4	CP30967-003-H	POLY BAG		
5	RM-C364-1H	RIMOCON UNIT		
6	CP30966-001-H	POLY BAG		
△ 7	LCT0748-001A-H	INST BOOK		
△ 8	LCT0749-001A-H	DIGEST MANUAL		

## REMOTE CONTROL UNIT PARTS LIST (RM-C364-1H)

△ Ref.No.	Part No.	Part Name	Description	Local
	3139 224 20073	BATTERY COVER		





# JVC

VICTOR COMPANY OF JAPAN, LIMITED  
TELEVISION RECEIVER DIVISION 1106 Heta, Iwai-city, Ibaraki-prefecture, 306-0698, Japan

